

# inta

---

## Enzo

### Concealed Shower Mixing Valve

#### EN40010CP

### Installation and Maintenance Instructions

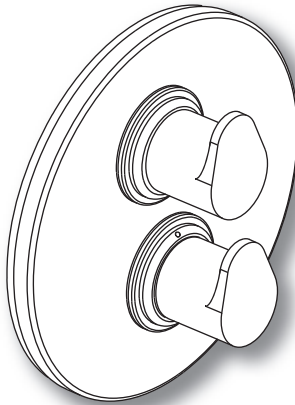

# inta

**Intatec Ltd**

Airfield Industrial Estate

Hixon

Staffordshire

ST18 0PF

In this procedure document we have endeavoured to make the information as accurate as possible.

We cannot accept any responsibility should it be found that in any respect the information is inaccurate or incomplete or becomes so as a result of further developments or otherwise.

Tel: **01889 272 180**

Fax: **01889 272 181**

email: [sales@intatec.co.uk](mailto:sales@intatec.co.uk)

web: [www.intatec.co.uk](http://www.intatec.co.uk)

## Introduction

This installation guide has been produced for the Enzo thermostatic concealed shower. These instructions cover the installation, operation and maintenance. Please read the enclosed instructions before commencing the installation of this product, please note;

**We recommend that the installation of any Inta product is carried out by an approved installer.**

The installation must be carried out strictly in accordance with the Water Supply (Water Fitting) Regulations 1999 and any local authority regulations.

If in doubt, we would recommend that you contact either your local water authority, the secretary of the Water Regulations Committee at WRc on Tel: 01495 248454 or Institute of Plumbing on Tel: 01708 472791.

All products **MUST** be re-commissioned to suit site conditions to ensure optimum performance levels of the product are obtained.

## Safety

This thermostatic shower must be installed and commissioned correctly to ensure that water is supplied at a safe temperature to suit the users.

43°C is the maximum mixed water temperature from a shower mixer. The maximum temperature takes account of the allowable tolerances inherent in thermostatic shower mixers and temperature losses.

**It is not a safe washing Temperature for adults or children.**

The British Burns Association recommends 37 to 37.5°C as a comfortable washing temperature for children. In premises covered by the Care Standard Act 2000, the maximum mixed water outlet temperature is 43°C.

## Products

Enzo Thermostatic Concealed Shower - single outlet.

EN40010CP

## Components - Shower Valve

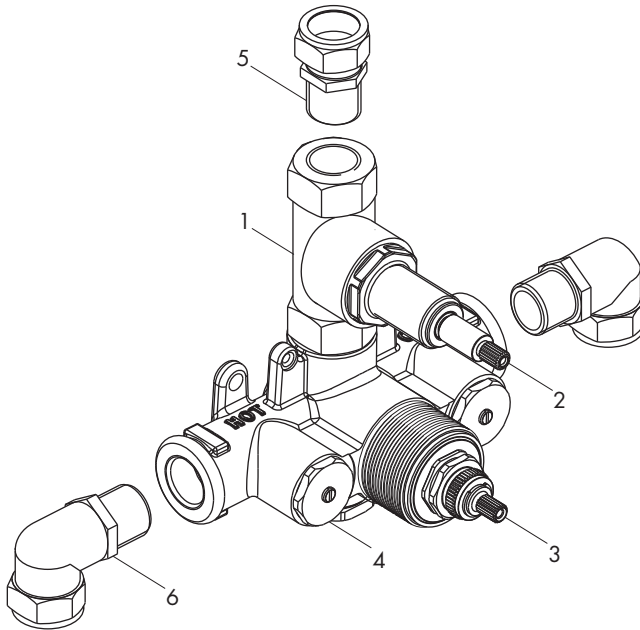

| Item | Qty | Component                           |
|------|-----|-------------------------------------|
| 1    | 1   | Valve body and flow controller body |
| 2    | 1   | Flow controller                     |
| 3    | 1   | Thermostatic cartridge              |
| 4    | 1   | Cap and check valve                 |
| 5    | 1   | Straight male x compression adaptor |
| 6    | 2   | Angled male x compression adaptor   |

## Components - Concealing Plate and Control Knobs

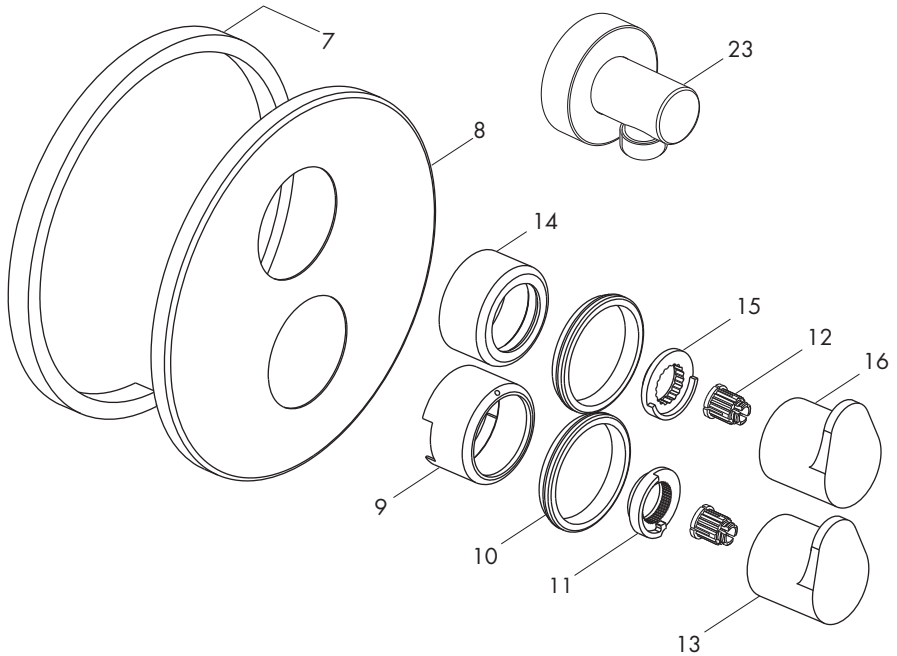

| Item | Qty | Component                                    |
|------|-----|--|
| 7    | 1   | Concealing plate gasket                      |
| 8    | 1   | Concealing plate                             |
| 9    | 1   | Temperature control concealing sleeve        |
| 10   | 2   | Sealing ring                                 |
| 11   | 1   | Temperature stop ring                        |
| 12   | 2   | Gear Drive                                   |
| 13   | 1   | Temperature control knob                     |
| 14   | 1   | Flow control concealing sleeve               |
| 15   | 1   | Flow control stop ring                       |
| 16   | 1   | Flow control knob                            |
| 23   | 1   | Outlet elbow                                 |
| 24*  | 1   | Overhead soaker - only supplied with EZ40013 |

\* Not shown

## Components - Plaster Guard and Insulation

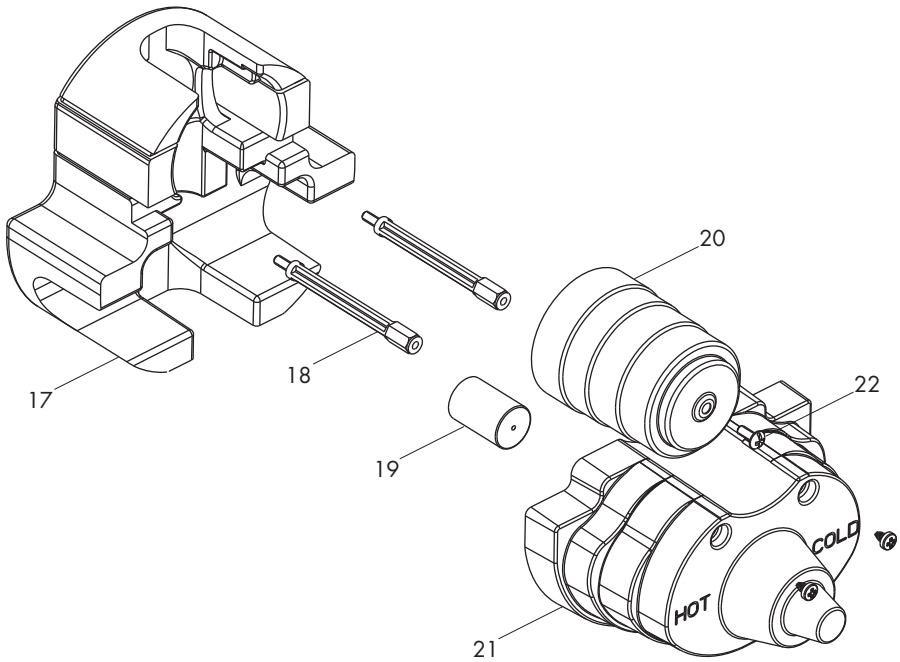

| Item | Qty | Component                        |
|------|-----|----------------------------------|
| 17   | 1   | Preformed body insulation shell  |
| 18   | 2   | Extension piece                  |
| 19   | 1   | Thermostatic cartridge extension |
| 20   | 1   | Flow controller cover            |
| 21   | 1   | Plaster guard                    |
| 22   | 3   | Retaining screw                  |

## Check Content

Before commencing remove all components from packaging and check each component with the contents list.

Ensure all parts are present, before discarding any packaging. If any parts are missing, do not attempt to install your Inta shower valve until the missing parts have been obtained.

## Technical Data

This Inta Enzo thermostatic shower valve is suitable for installations on all types of plumbing systems, including gravity supplies, fully pumped, modulating combination boiler, unvented water heater and unbalanced supplies i.e. Cold Mains & Tank Fed Hot. They are not suitable for non-modulating combination boilers.

|                                  |         |                              |      |
|----------------------------------|---------|------------------------------|------|
| Max Inlet Pressure (Static)      | 10 bar  | Max Inlet Temperature        | 85°C |
| Max Inlet Pressure (Dynamic)     | 5 bar   | Pre Set Factory Temp Setting | 38°C |
| Min Operating Pressure (Dynamic) | 0.2 bar | Temperature Stability        | ±2°C |
| Max Unbalanced Pressure Ratio    | 5:1     | Min Temp Differential to     |      |
| Inlet Connections (Body only)    | 15mm    | ensure fail-safe between hot |      |
| Outlet Connection                | Top     | and cold supplies            | 10°C |

## Unvented Mains Pressure System

The drawing shows a typical installation of a shower mixing valve in conjunction with an unvented hot water system. This type of installation must be carried out in accordance with Part G of the Building Regulations.

Whilst pressures are theoretically equal (balanced) most unvented hot systems have a pressure reducing valve on the incoming cold water prior to the hot water storage vessel. This means that the hot and cold pressures can be significantly different.

Most unvented systems use an inlet manifold located directly after the pressure reducing valve.

It is recommended that the cold supply be taken from one of the outlets of the manifold directly to the shower as an independent supply.

For systems without a manifold unit after the pressure reducing valve and where the cold water supply pressure is significantly higher than the hot supply we recommend that a separate pressure reducing valve is fitted to the cold supply, as close as possible to the shower valve and with no draw off points between it and the shower valve.

Flow regulators are required for installations where a PRV is not fitted to ensure simultaneous demand is accounted for.

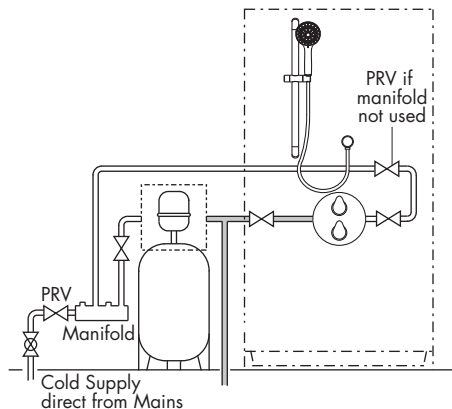

## Pumped Systems

Pumped systems use a booster pump to increase the pressure of the gravity fed water supplies.

These booster pumps are used where the head of water is insufficient to provide a satisfactory shower or where a high performance shower is required.

Please ensure that the performance of the pump is matched to suit the shower.

Follow the instructions for gravity fed installations taking into account the installation requirements of the pump.

Ensure that the hot and cold water storage capacity is sufficient to supply the shower and any other draw off points that may be used simultaneously.

**Most pumps require a minimum head of water to allow the flow switches to operate automatically. Where this is not available a negative head kit may be required to operate the pump.**

Please consult the pump manufacturer's installation requirements

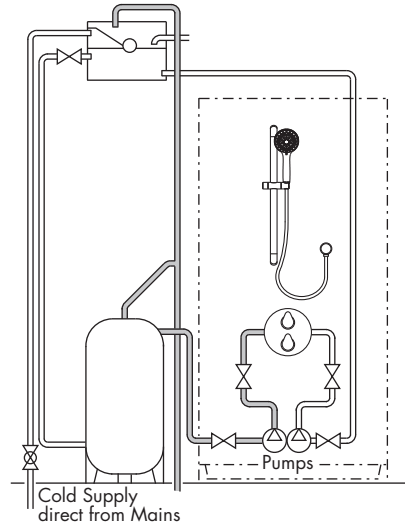

## Modulating Combi Boiler / Instantaneous Gas Water Heater

The drawing shows a typical installation of a shower valve in conjunction with a combination boiler.

Combi boilers will produce a constant flow of water at a temperature within its operating range. However we recommend that the system should supply hot water in excess of 60°C.

The hot water flow rates are dependant upon the type of boiler / heater used and the temperature rise required to heat the cold water to the required temperature.

The cold water flow rates may be much greater as they are generally unrestricted from the mains cold water supply. To ensure relatively balanced flow rates, we recommend that a pressure reducing valve or 6 l/min flow regulator is fitted in the cold water supply pipe.

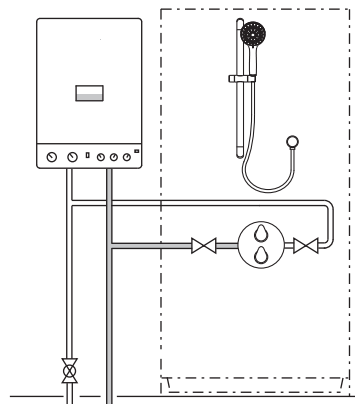

## Gravity System

The drawing shows a typical installation of a shower valve on a gravity supplied system.

Please note the minimum head pressure required to ensure correct operation of the valve. In accordance with good plumbing practice, we recommend that a totally independent hot and cold water supply be taken to the valve.

The cold water supply must be connected directly to the water cistern. The hot water supply should be connected to the hot water cylinder via an Essex flange or Sussex flange or to the vent or a draw off pipe as close as possible to the top of the cylinder.

For equal tank fed pressures there is no need to fit the flow regulators. This installation is the recommended minimum for gravity supplies.

For systems with less than 2 metre head pressure, we recommend that a suitable booster pump is fitted to increase the supply pressure.

### Cold Mains & Gravity Hot Supplies

If the cold supply to the shower is direct from the cold water mains and the hot water supply is gravity fed from the cold water cistern via the hot water cistern you **MUST** fit a pressure reducing valve or a 6 l/min flow regulator.

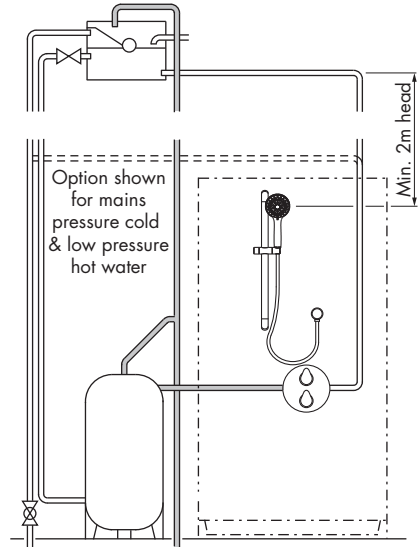

## Dimensions

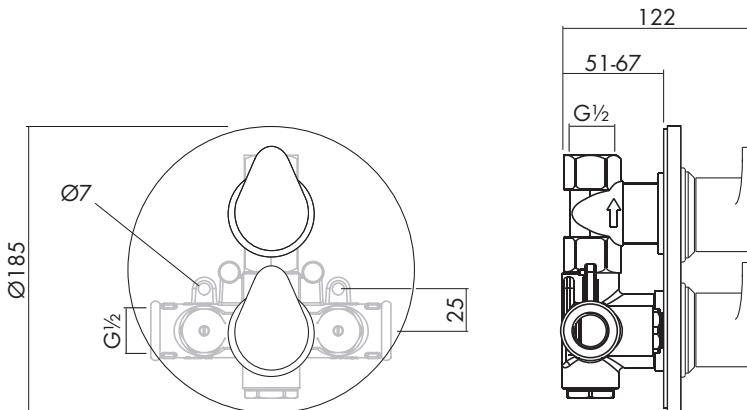



---

## Site Preparation

**It is important to plan the installation thoroughly to suit site conditions before commencing.**

- Before commencing the installation ensure site conditions are suitable.
- The shower mixing valve is designed for concealed pipework, whether in a solid or studded wall.
- Site conditions will determine how the shower valve, outlet elbow and if required the over head soaker (shower head) will be installed.
- The thickness of wall tiles, plaster or plaster board should all be considered when positioning the shower valve and routing the hot and cold supply pipes.
- The shower valve must protrude sufficiently from the finished tiled surface to allow the concealing plate and control knobs to be fitted.
- Ensure the shower valve will be vertical when installed.
- The supply pipes can come from below, above, the side or through the wall.
- The shower valve must be installed securely into the wall. If not embedded into the wall with plaster the shower valve must be fixed secure to the studding using screws in the 2 mounting holes.
- The whole system should be thoroughly flushed, prior to the connection of the hot and cold water supplies to the shower valve, to remove any debris that may be in the supply pipework.
- Ensure there are no joint leaks before finishing the wall.
- Isolation valves must be fitted in an accessible position to both the hot and cold supplies should the valve need to be isolated in the future for servicing.

## Installation - Shower Valve

Before installing the shower valve, fit the three threaded by compression fittings (5 & 6) to the two inlet connections and the outlet connection, ensuring water tight joints. Also connect the supply and outlet pipes.

The valve and pipes can be used as a template to mark their position onto the wall.

## Solid wall

- Create a large enough cavity for the shower valve and chase the wall for the two supply pipes and a route from the outlet of the shower valve to the outlet elbow and overhead shower.
- If the shower valve is to be fitted in an outside wall or where there is a greater risk of freezing the preformed insulation (18) should be used, which will require a deeper cavity.
- If the preformed insulation is not used, fix the shower valve into the cavity using the 2 fixing holes ensuring the valve is vertically in line.
- Ensure the thermostatic cartridge and flow control valve protrude sufficiently from the finished wall surface to allow the concealing plate and control knobs to be fitted, see dimension drawing.

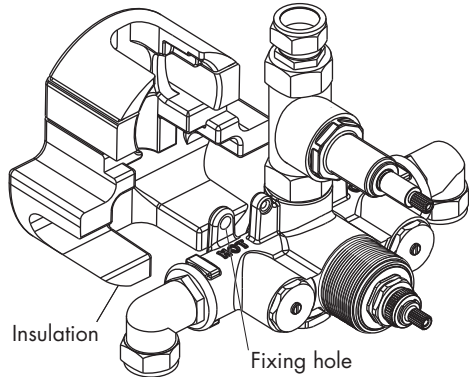

## Cavity wall

- The shower valve must be fixed securely to the structural members of the stud wall and/or an additional member may need to be included where the shower valve will be located.
- If there is access from the adjacent room into the cavity, the surface of the shower room wall can be finished with most of the tiling completed.
- Fix the shower valve to the structural member using 2 screws of sufficient length and tighten to hold secure.
- Ensure the thermostatic cartridge and flow control valve protrude sufficiently from the finished wall surface to allow the concealing plate and control knobs to be fitted, see dimension drawing for protrusion distance.
- Additional holes need to be made for the outlet elbow and soaker arm. The tiling around these holes needs to be completed to allow these components to be fitted.

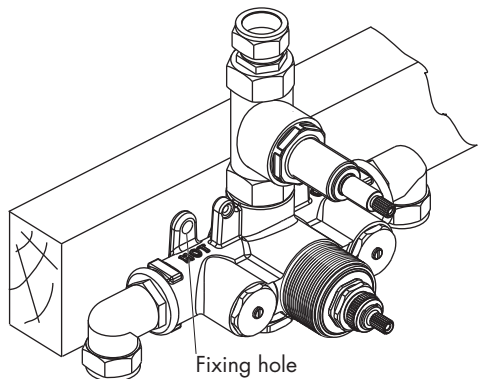

## Plaster guard

- Check all joints for leakage before embedding into the wall or concealing the valve.
- Screw the extension pieces (18) into the two threaded holes.
- Place the thermostatic cartridge extension (19) over the flow cartridge spindle.
- Place the flow control cover (20) over the flow control valve and secure with the retaining screw (22).
- Fit the plaster guard (21) over the valve and secure with two retaining screws (22).
- For a solid wall embed the pipes and shower valve with plaster.
- Finally finish the wall with plaster and plaster up to and around the plaster guard.
- When the plaster is dry remove the plaster guard or if a tiled wall leave in position and tile around the guard.
- Finally remove the retaining screws, plaster guard and extension pieces.

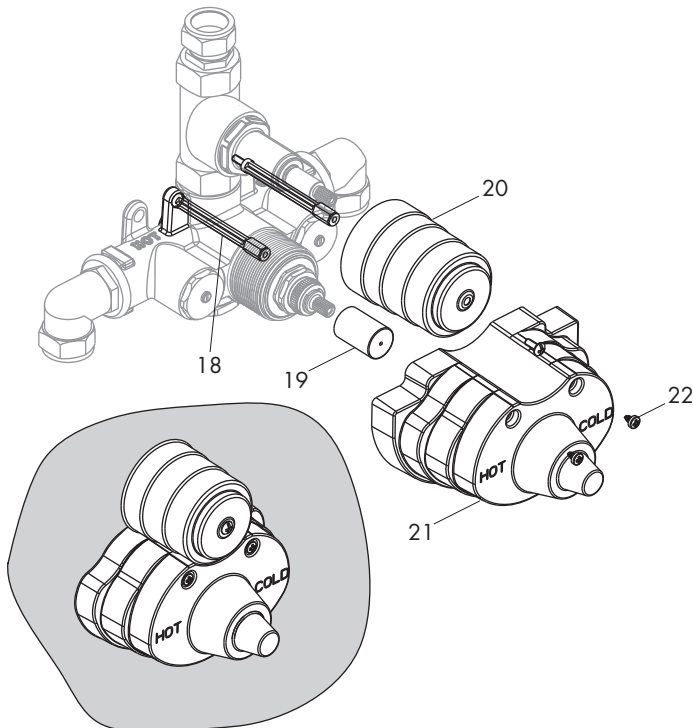

## Installation - Outlet Elbow and Concealing Plate

- If there is access from the adjacent room into the cavity, the surface of the shower room wall can be finished with most of the tiling completed.
- Apply mastic to the back of the flange, close to the edge, of the outlet elbow before inserting through the hole in the wall and secure with a back nut
- Connect the outlet elbow to its copper supply pipework ensuring a water tight joint and connect to the shower valve.
- The pipework should be secured where possible to a structural member.
- Turn on the water supplies and test all joints for leakage before finishing the wall. Any leaking joints must be rectified before proceeding further.
- Finish tiling the wall around the shower valve.
- Fit the gasket into the concealing plate with a bead of mastic.
- Place the concealing plate and gasket, with a bead of mastic on the back of the gasket, over the control valves and press firmly to the wall.
- Fit the stop rings and control knobs.
- Finally finish the wall on the adjacent room side.

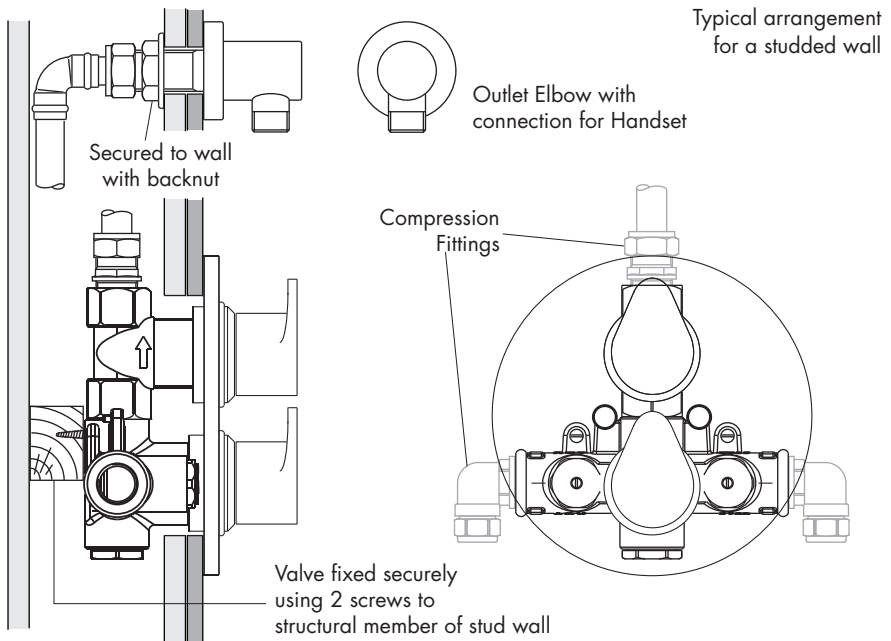

## Installation - Overhead Soaker and Concealing Plate

- If there is access from the adjacent room into the cavity, the surface of the shower room wall can be finished with most of the tiling completed.
- Apply mastic to the back of the flange, close to the edge, of the overhead soaker before inserting through the hole in the wall and secure with a back nut
- Connect the overhead soaker to its copper supply pipework ensuring a water tight joint and connect to the shower valve.
- The pipework should be secured where possible to a structural member.
- Turn on the water supplies and test all joints for leakage before finishing the wall. Any leaking joints must be rectified before proceeding further.
- Finish tiling the wall around the shower valve.
- Fit the gasket into the concealing plate with a bead of mastic.
- Place the concealing plate and gasket, with a bead of mastic on the back of the gasket, over the control valves and press firmly to the wall.
- Fit the stop rings and control knobs.
- Finally finish the wall on the adjacent room side.

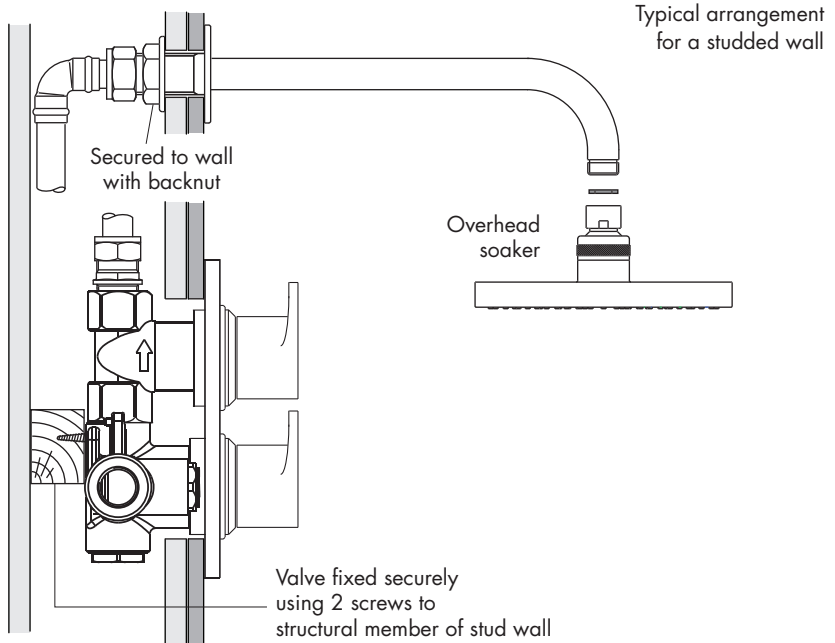

## Calibration

The Enzo shower valve has a factory set outlet temperature of 38°C via the security setting. This is based on a balanced supply pressure and a stable hot water inlet temperature of 65°C.

However, the calibration point **MUST** be checked and re-set as necessary to suit site conditions.

Care must be taken when re-calibrating the valve as **INCORRECT CALIBRATION CAN CAUSE INJURY**.

- Remove the temperature control knob (13) by pulling away from the shower valve and the temperature stop ring (11).
- Fully open the flow control and allow the outlet temperature to stabilise.
- Temporarily refit the control knob (13) onto the gear drive (12) and using a digital thermometer it is possible to increase or reduce the mixed water outlet temperature until 38°C is re-established, by slowly rotating the control knob.
- Remove the control knob (13) and refit the temperature stop ring (11) onto the splined section of the cartridge. The red dot on the temperature stop ring must align with the temperature position symbol on the temperature control concealing sleeve (10).
- Refit the temperature control knob in the reverse order ensuring that 38°C on the control knob is in line with the temperature position symbol (10).

**PLEASE NOTE THAT ONCE CALIBRATED, THE SECURITY SETTING WILL ONLY BE 38°C UNDER THE SUPPLY CONDITIONS USED FOR CALIBRATION.**

## Cartridge Replacement

- Isolate both the hot and cold water supplies
- Remove the temperature control knob (13) by pulling away from the shower valve, the gear drive (12) and the temperature stop ring (11).
- Using a suitable spanner unscrew the cartridge (3).
- Replace with a new cartridge.
- Refit the gear drive (12).
- The shower valve must be re-calibrated after fitting the new cartridge following the procedure above.
- Refit the temperature stop ring (11) onto the splined section of the cartridge. The red dot on the temperature stop ring must align with the temperature position symbol on the temperature control concealing sleeve (10).
- Refit the temperature control knob in the reverse order ensuring that 38°C on the control knob is in line with the temperature position symbol (10).

## Cartridge Replacement

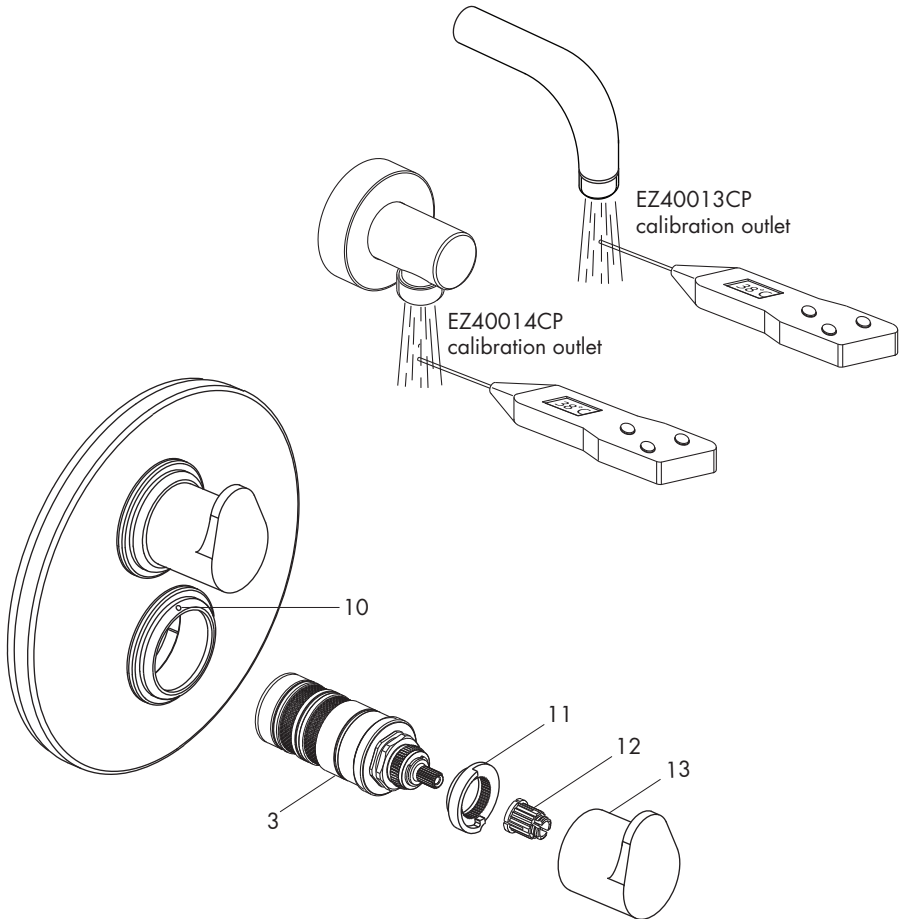

## Aftercare

Inta shower mixing valves have a high quality finish and should be treated with care.

An occasional wipe with a mild washing-up liquid on a soft damp cloth followed by a thorough rinsing is all that is required.

The nozzles in the hand set should be cleaned periodically to remove any build up of debris or deposits which may affect the performance of the shower.

**Do not use an abrasive or chemical household cleaner** as this may **cause damage**.

## Spares

A full range of spares are available for this product.

**PLEASE NOTE:** Only genuine spares should be used.

## Problem Solving

The following details are supplied for on site queries, should you require any further assistance our Technical Department can be contacted directly on 01889 272199.

| Fault   | Solution  |
|---|---|
| Showering temperature is not hot enough.  | Ensure the hot water supply is at a constant temperature above 60°C.<br>Check for air locks in the pipework.  |
| The water goes cold during showering.   | Insufficient stored hot water.<br>When used with a combi boiler confirm that the boiler is still firing.<br>Adjust the boiler to a minimum setting of 65°C which may not necessarily be the best flow rate. |
| When the water is set at cold, the showering temperature is too hot.                | The hot and cold supply connections have been made in reverse.  |
| The maximum showering temperature is too hot or when set to hot water runs to cold. | Check the commissioned maximum temperature of the shower valve.<br>Check the connections to the valve have not been made in reverse.  |
| The flow of water from the shower valve is low.                                     | Check the filters are clean and the supply pressure is above 0.4 bar.   |
| No flow of water  | Ensure the valve has not fail-safed and check that there is hot and cold water flow to the valve.<br>Ensure the check valves are not closed.  |



## Installing the Flexible Handset

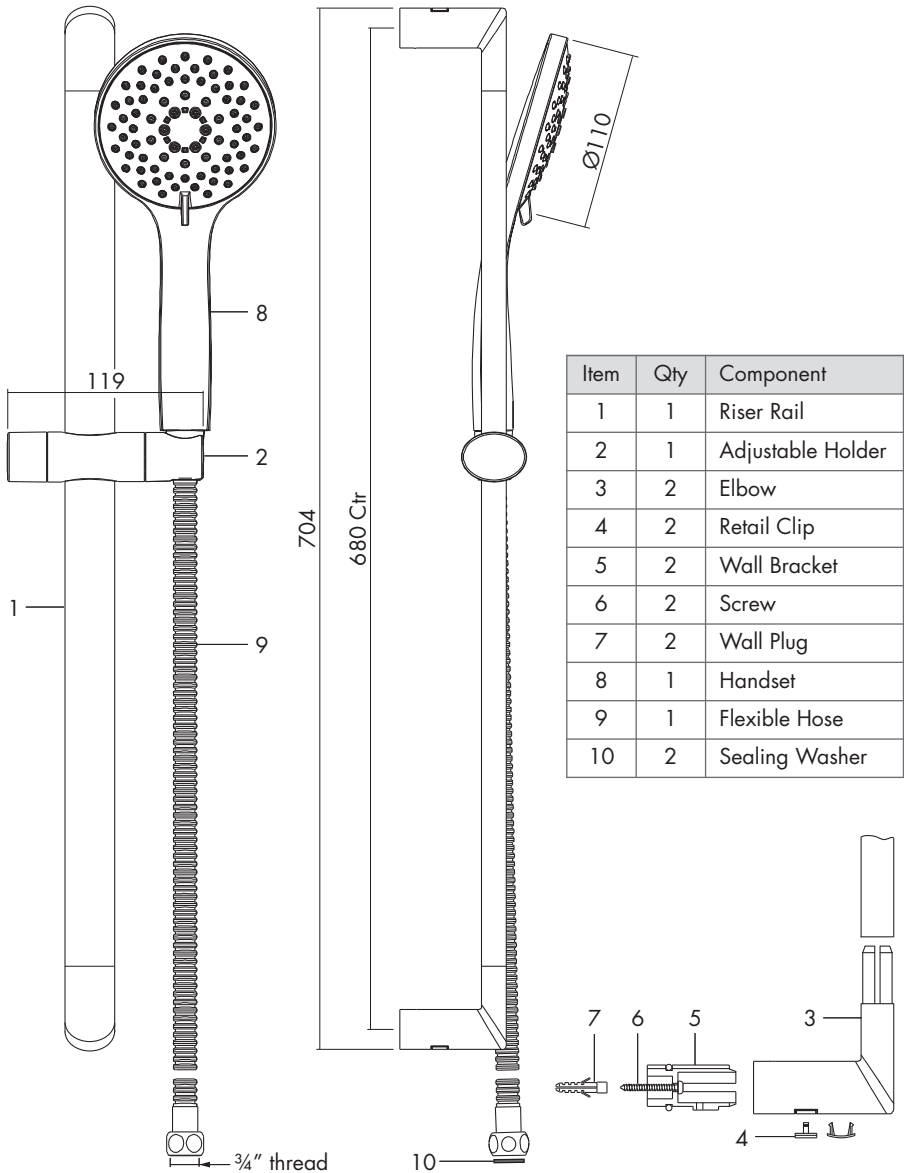

Note: drawing for illustration purposes only

## Installing the Riser Rail

The screws and wall plugs supplied are only suitable for use in solid walls. If the wall is plaster board or soft building block use special wall plugs obtainable from most DIY stores.

Ensure there are no supply pipes or cables where you intend to drill.

Where possible, drill holes between ceramic tiles (in the grout). If drilling into ceramic tiles use a ceramic bit.

This product must always be used and fitted in such a way as not to cause water damage, therefore should be located and directed towards a suitable bath or shower tray.

Take care to use power tools safely.

Drill the 6mm diameter hole for the lower wall bracket (5).

To avoid cracking ensure the wall plug is pushed all the way behind the ceramic tile.

Using the 35mm long screw provided (6) secure the wall bracket (5) to the wall ensuring the correct orientation for the bracket with the hole for the clip (4) at the bottom.

Assemble the handset holder onto the riser rail as illustrated.

Push the two elbows (3) fully into the riser rail (1).

Assemble the riser rail with the two elbows onto the lower wall bracket and ensure the riser rail is vertical.

Mark round the upper elbow with a removeable marker onto the wall.

Position the top wall bracket onto the wall within the markings and using the hole as a template drill a 6mm diameter hole.

Fix the upper wall bracket to the wall using the 35mm long screw (6) and ensure the hole for the clip is at the top.

Refit the riser rail and elbows onto the two wall brackets and hold in position by inserting the plastic clips (4) into the hole in each elbow.

Ensure the sealing washers (10) are inserted into both ends of the flexible hose and connect the hose to the shower valve and the handset (8).

Turn on the shower valve and check joints for leakage.



# inta

---

## **Please leave this Manual for the User**

To activate your product warranty please visit

**[www.intatec.co.uk](http://www.intatec.co.uk)**

and click on Product Registration

# inta

**Intatec Ltd**

Airfield Industrial Estate

Hixon

Staffordshire

ST18 0PF

Tel: **01889 272 180**

Fax: **01889 272 181**

email: **[sales@intatec.co.uk](mailto:sales@intatec.co.uk)**

web: **[www.intatec.co.uk](http://www.intatec.co.uk)**

E & O.E

© Intatec Ltd 2017

02-06-17