

inta

PURO

Sequential Shower Valve

PU79010CP, PU79011CP & PU79020CP

Installation and Maintenance Instructions

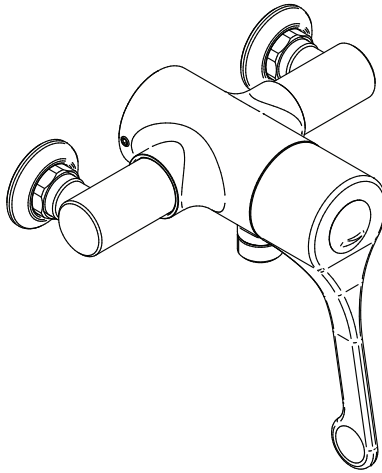

Intatec Ltd

Airfield Industrial Estate
Hixon
Staffordshire
ST18 0PF

In this procedure document we have endeavoured to make the information as accurate as possible.

We cannot accept any responsibility should it be found that in any respect the information is inaccurate or incomplete or becomes so as a result of further developments or otherwise.

Tel: **01889 272 180**

Fax: **01889 272 181**

email: **sales@intatec.co.uk**

web: **www.intatec.co.uk**

Introduction

This installation guide has been produced for the Puro range of single outlet thermostatic shower valves. These instructions cover the installation, operation and maintenance. Please read the enclosed instructions before commencing the installation of this product, please note;

We recommend that the installation of any Inta product is carried out by an approved installer.

The installation must be carried out strictly in accordance with the Water Supply (Water Fitting) Regulations 1999 and any local authority regulations.

If in doubt we recommend that you contact WRAS - Water Regulations Advisory Scheme on Tel: 0333 207 9030, your local water authority - details available on the WRAS website or the Chartered Institute of Plumbing and Heating Engineers on Tel: 01708 472 791.

All products **MUST** be re-commissioned to suit site conditions to ensure optimum performance levels of the product are obtained.

Safety

Inta thermostatic showers must be installed and commissioned correctly to ensure that water is supplied at a safe temperature to suit the users.

The showers are pre-set using ideal conditions to 38°C.

The maximum mixed temperature takes account of the allowable tolerances inherent in thermostatic shower mixers and temperature losses.

It is not a safe bathing temperature for adults or children.

The British Burns Association recommends 37 to 37.5°C as a comfortable bathing temperature for children. In premises covered by the Care Standard Act 2000, the maximum mixed water outlet temperature is 43°C.

Products

Puro Exposed Sequential Shower Valve - Bottom Outlet	PU79010CP
Puro Exposed Sequential Shower Valve - Top Outlet	PU79011CP
Puro Concealed Sequential Shower Valve	PU79020CP

Check Content

Before commencing remove all components from packaging and check each component with the contents list.

Ensure all parts are present, before discarding any packaging. If any parts are missing, do not attempt to install your Puro shower valve until the missing parts have been obtained.

Components - Exposed

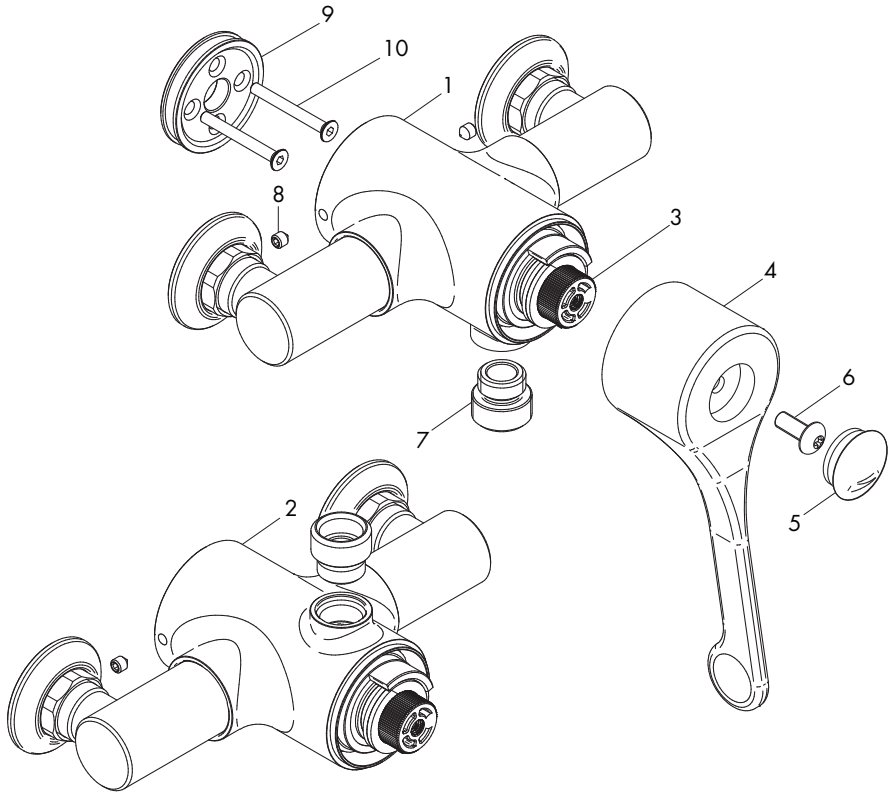

Item	Qty	Component	Item	Qty	Component
1	1	Valve body - PU79010CP	6	1	Retaining screw
2	1	Valve body - PU79011CP	7	1	Outlet fitting
3	1	Thermostatic cartridge	8	2	Grub screw
4	1	Lever	9	1	Wall plate
5	1	Cap	10	2	Screw

Components - Concealed

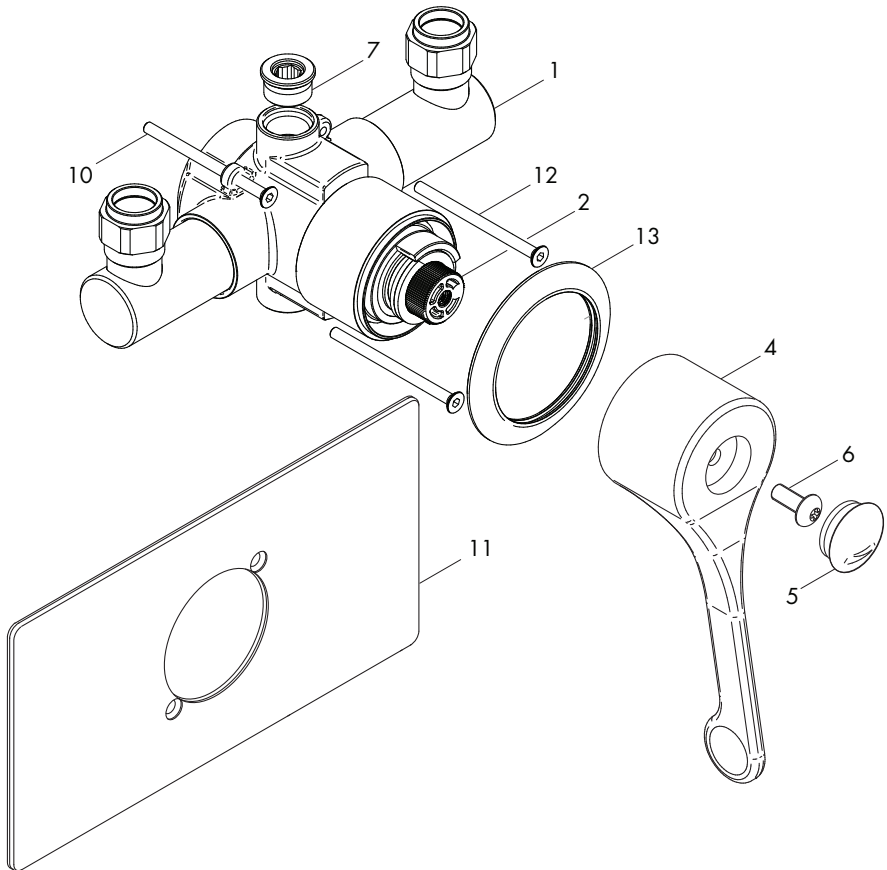

Item	Qty	Component	Item	Qty	Component
1	1	Valve body - PU79020CP	7	1	Outlet plug
3	1	Thermostatic cartridge	10	2	Wall fixing screw
4	1	Lever	11	1	Rectangular concealing plate
5	1	Cap	12	2	Plate fixing screw
6	1	Retaining screw	13	1	Concealing plate - small

Dimensions - PU79010CP and PU79011CP

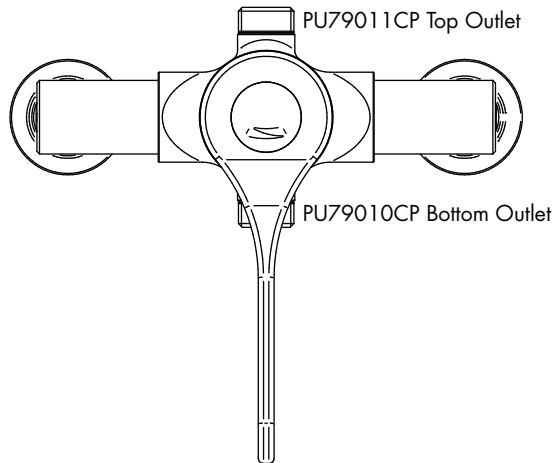
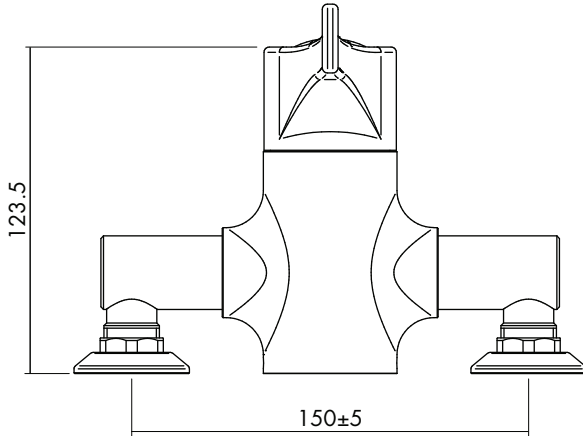

Dimensions - PU79020CP

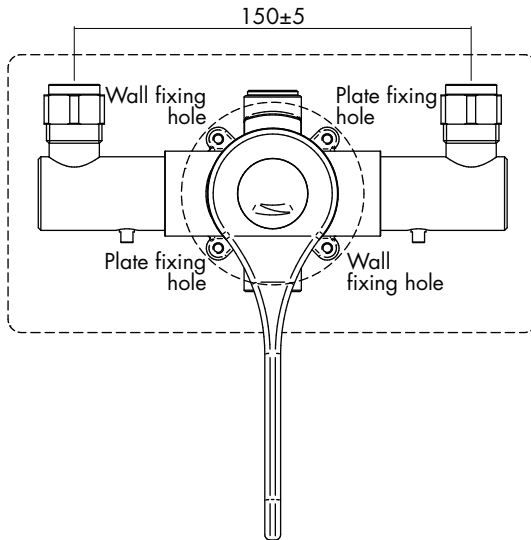
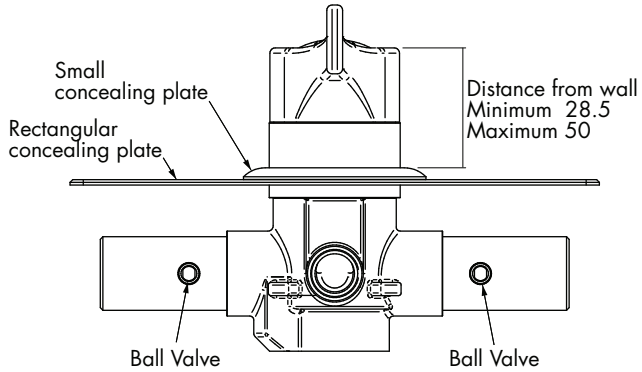

Technical Data

The Inta Puro thermostatic shower valve is suitable for installations on all types of plumbing systems, including gravity supplies, fully pumped, modulating combination boiler, unvented water heater and unbalanced supplies i.e. Cold Mains & Tank Fed Hot. They are not suitable for non-modulating combination boilers.

Max Inlet Pressure (Static)	10 bar	Max Inlet Temperature	85°C
Max Inlet Pressure (Dynamic)	5 bar	Pre Set Factory Temp Setting	38°C
Min Operating Pressure (Dynamic)	0.2 bar	Temperature Stability	±2°C
Max Unbalanced Pressure Ratio	5:1	Min Temp Differential to	
Inlet Connections (Body only)	15mm	ensure fail-safe between hot	
Outlet Connection	½"	and cold supplies	10°C

Unvented Mains Pressure System

The drawing shows a typical installation of a shower mixing valve in conjunction with an unvented hot water system. This type of installation must be carried out in accordance with Part G of the Building Regulations.

Whilst pressures are theoretically equal (balanced) most unvented hot systems have a pressure reducing valve on the incoming cold water prior to the hot water storage vessel. This means that the hot and cold pressures can be significantly different.

Most unvented systems use an inlet manifold located directly after the pressure reducing valve.

It is recommended that the cold supply be taken from one of the outlets of the manifold directly to the shower as an independent supply.

For systems without a manifold unit after the pressure reducing valve and where the cold water supply pressure is significantly higher than the hot supply we recommend that a separate pressure reducing valve is fitted to the cold supply, as close as possible to the shower valve and with no draw off points between it and the shower valve.

Flow regulators are required for installations where a PRV is not fitted to ensure simultaneous demand is accounted for.

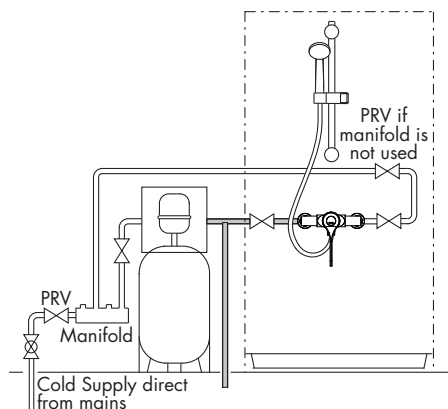

Pumped Systems

Pumped systems use a booster pump to increase the pressure of the gravity fed water supplies.

These booster pumps are used where the head of water is insufficient to provide a satisfactory shower or where a high performance shower is required.

Please ensure that the performance of the pump is matched to suit the shower.

Follow the instructions for gravity fed installations taking into account the installation requirements of the pump.

Ensure that the hot and cold water storage capacity is sufficient to supply the shower and any other draw off points that may be used simultaneously.

Most pumps require a minimum head of water to allow the flow switches to operate automatically. Where this is not available a negative head kit may be required to operate the pump.

Please consult the pump manufacturer's installation requirements

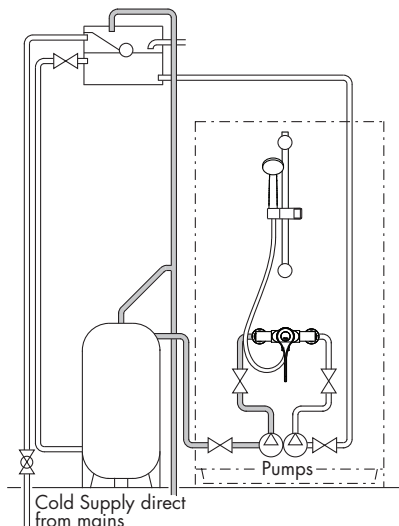

Modulating Combi Boiler / Instantaneous Gas Water Heater

The drawing shows a typical installation of a shower valve in conjunction with a combination boiler.

Combi boilers will produce a constant flow of water at a temperature within its operating range. However we recommend that the system should supply hot water in excess of 60°C.

The hot water flow rates are dependant upon the type of boiler / heater used and the temperature rise required to heat the cold water to the required temperature.

The cold water flow rates may be much greater as they are generally unrestricted from the mains cold water supply. To ensure relatively balanced flow rates, we recommend that a pressure reducing valve or 6 l/min flow regulator is fitted in the cold water supply pipe.

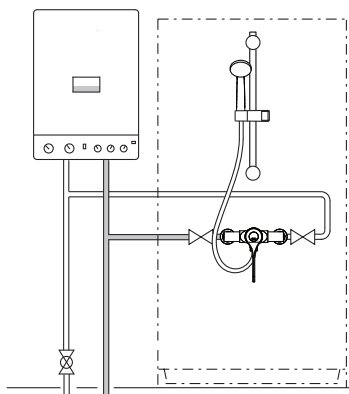

Gravity System

The drawing shows a typical installation of a shower valve on a gravity supplied system.

Please note the minimum head pressure required to ensure correct operation of the valve. In accordance with good plumbing practice, we recommend that a totally independent hot and cold water supply be taken to the valve.

The cold water supply must be connected directly to the water cistern. The hot water supply should be connected to the hot water cylinder via an Essex flange or Sussex flange or to the vent or a draw off pipe as close as possible to the top of the cylinder.

For equal tank fed pressures there is no need to fit the flow regulators. This installation is the recommended minimum for gravity supplies.

For systems with less than 2 metre head pressure, we recommend that a suitable booster pump is fitted to increase the supply pressure.

Cold Mains & Gravity Hot Supplies

If the cold supply to the shower is direct from the cold water mains and the hot water supply is gravity fed from the cold water cistern you **MUST** fit a pressure reducing valve or a 6 l/min flow regulator.

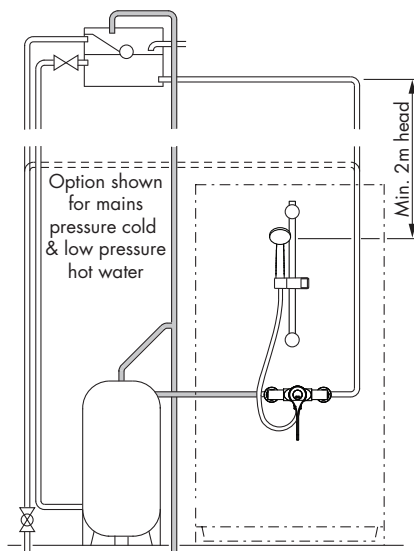

Site Preparation

It is important to plan the installation thoroughly to suit site conditions before commencing.

- Before commencing the installation ensure site conditions are suitable.
- Site conditions will determine how the shower valve will be installed.
- The thickness of wall tiles, plaster or plaster board should all be considered when positioning the shower valve and routing the hot and cold supply pipes.
- Ensure the shower valve will be horizontal when installed.
- The shower valve must be installed securely into the wall using the method provided.
- The whole system should be thoroughly flushed, prior to the connection of the hot and cold water supplies to the shower valve, to remove any debris that may be in the supply pipework.
- Isolation valves must be fitted in an accessible position to both the hot and cold supplies should the valve need to be isolated in the future for servicing.

Installation - PU79010CP & PU79011CP Exposed Shower Valve

The valve requires the supply pipework to have 150mm centres and sufficient copper pipe must protrude from the finished tiled surface to allow a water tight compression joint to be made.

The shower mixing valve is designed for concealed pipework, whether in a solid or studed wall.

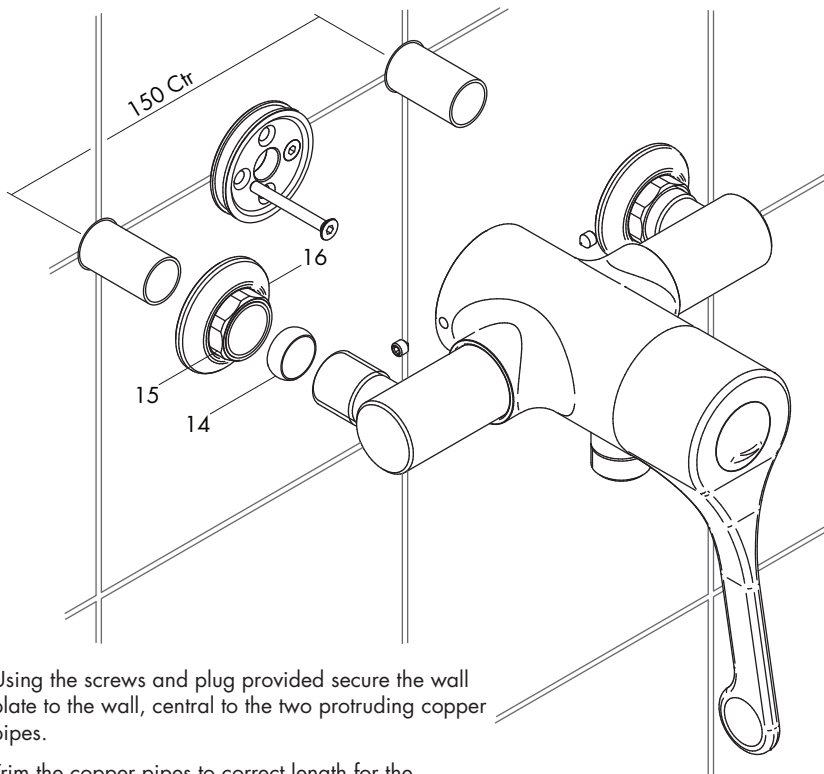

Using the screws and plug provided secure the wall plate to the wall, central to the two protruding copper pipes.

Trim the copper pipes to correct length for the compression joints.

Run a bead of sealant onto the back of the concealing plates (16) close to the outer edge.

Loosen the compression nuts (15).

Fit the shower valve over the copper pipes and locate onto the wall plate.

Ensure the concealing plates (16) are pressed onto the wall before tightening the grub screws (8) and the compression nuts (15).

Turn on the water supplies and check for signs of leakage.

Installation - PU79020CP concealed Shower Valve

The shower mixing valve is designed for concealed pipework, whether in a solid or studded wall.

The inlet connections can be rotated to suit the direction of the supply pipes.

The outlet connection can be upwards or downward by inserting the outlet plug (7) into the port which is not required.

The shower valve can be used as a template to mark its position onto the wall.

Remove the cap (5), retaining screw (6) and the lever (7).

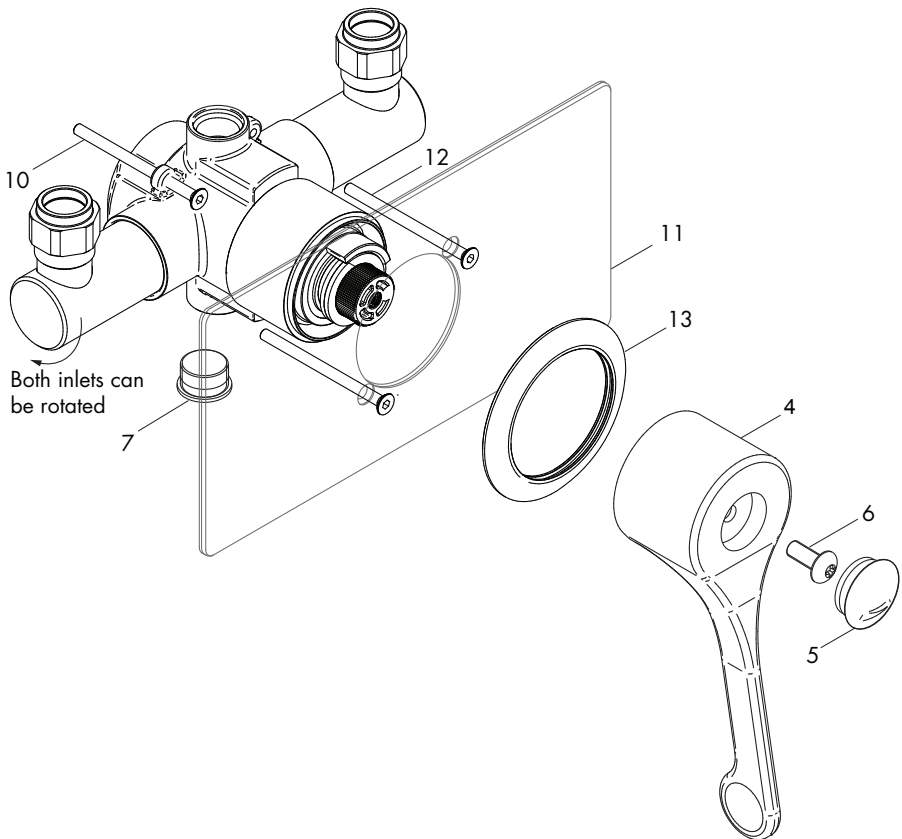

Solid wall

- Create a large enough cavity for the shower valve and chase the wall for the two supply pipes and a route from the outlet of the shower valve to the water outlet.
- Fix the shower valve into the cavity using the 2 fixing screws (10) ensuring the valve is horizontal.
- Connect the two supply pipes and the outlet pipe to the shower valve and close the two ball isolating valves on the opposite side to the supply pipe connection.
- Turn on the water supplies and check the compression joints for signs of leakage.
- Open both ball valves and turn on the shower valve so that the water runs from the handset or overhead shower and check the joint for signs of leakage.
- Finish and tile the wall.
- Run a bead of sealant onto the back of the concealing plates (9) close to the outer edge.
- Locate the rectangular concealing plate (11) onto the shower valve and secure in position adjacent to the wall with the plate retaining screws (8).
- Locate the circular concealing plate (13) onto the shower valve and push to the rectangular concealing plate (11) and re-assemble the lever onto the shower valve.

Cavity wall

- The shower valve must be fixed securely to the structural members of the stud wall and/or an additional member may need to be included where the shower valve will be located.
- If there is access from the adjacent room into the cavity, the surface of the shower room wall can be finished with most of the tiling completed.
- Fix the shower valve to the structural member using 2 screws (10) supplied ensuring the valve is horizontal.
- Ensure the shower valve protrude sufficiently from the finished wall surface to allow the concealing plates and control lever to be fitted.
- Connect the two supply pipes and the outlet pipe to the shower valve and close the two ball isolating valves on the opposite side to the supply pipe connection.
- Turn on the water supplies and check the compression joints for signs of leakage.
- Open both ball valves and turn on the shower valve so that the water runs from the handset or overhead shower and check the joint for signs of leakage.
- Run a bead of sealant onto the back of the concealing plate (11) close to the outer edge.
- Locate the rectangular concealing plate (11) onto the shower valve and secure in position adjacent to the wall with the plate retaining screws (12).
- Locate the circular concealing plate (13) onto the shower valve and push to the rectangular concealing plate (11) and re-assemble the lever onto the shower valve.

Calibration

The Puro shower valve has a factory set outlet temperature of 38°C via the security setting. This is based on a balanced supply pressure and a stable hot water inlet temperature of 65°C. However, the calibration point **MUST** be checked and re-set as necessary to suit site conditions.

Care must be taken when re-calibrating the tap as **INCORRECT CALIBRATION CAN CAUSE INJURY**.

- Remove the indice (5), retaining screw (6), handle (7) and the temperature stop ring (11).
- Temporarily refit the handle (7) and move to the position for the hottest water and allow the outlet temperature to stabilise.
- Using a digital thermometer it is possible to increase or reduce the mixed water outlet temperature until 38°C is re-established, by slowly rotating the handle.
- Remove the handle (7) and refit the temperature stop ring (17) onto the splined section of the cartridge at the maximum temperature position.
- Refit the handle in the reverse order.

PLEASE NOTE THAT ONCE CALIBRATED, THE SECURITY SETTING WILL ONLY BE 38°C UNDER THE SUPPLY CONDITIONS USED FOR CALIBRATION.

Cartridge Replacement

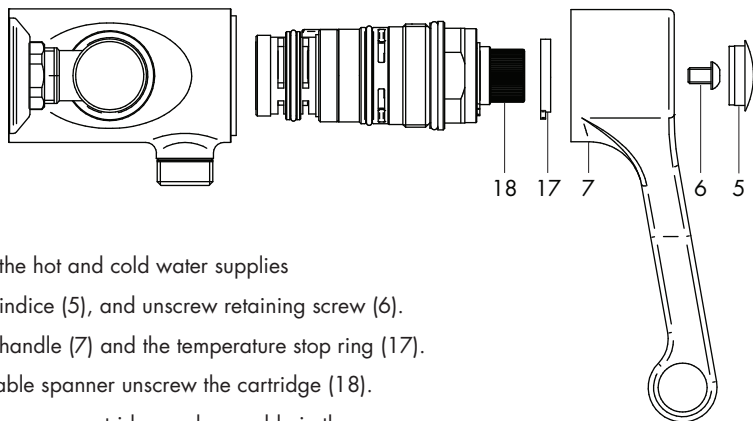

Isolate both the hot and cold water supplies

Remove the indice (5), and unscrew retaining screw (6).

Remove the handle (7) and the temperature stop ring (17).

Using a suitable spanner unscrew the cartridge (18).

Replace with a new cartridge and assemble in the reverse

Spares

A full range of spares are available for this product.

PLEASE NOTE: Only genuine spares should be used.

Problem Solving

The following details are supplied for on site queries, should you require any further assistance our Technical Department can be contacted on 01889 272199.

Fault	Solution
Showering temperature is not hot enough.	Ensure the hot water supply is at a constant temperature above 60°C. Check for air locks in the pipework. Thermostatic cartridge movement limited due to lime scale build up
The water goes cold during showering.	Insufficient stored hot water. When used with a combi boiler confirm that the boiler is still firing. Adjust the boiler to a minimum setting of 65°C which may not necessarily be the best flow rate.
When the water is set at cold, the showering temperature is too hot.	The hot and cold supply connections have been made in reverse. Thermostatic cartridge movement limited due to lime scale build up
The maximum showering temperature is too hot or when set to hot water runs too cold.	Check the commissioned maximum temperature of the shower valve. Check the connections to the valve have not been made in reverse. Thermostatic cartridge movement limited due to lime scale build up
The flow of water from the shower valve is low.	Check the filters are clean and the supply pressure is above 0.2 bar.
No flow of water	Ensure the valve has not fail-safed and check that there is hot and cold water flow to the valve. Ensure the check valves are not closed.
Shower is stiff to operate	Build-up of limescale on flow control cartridge - service and de-scale
Passing/dripping from outlet	Service flow control cartridge.

Inta TMV3 Thermostatic Shower Valve

Introduction

The Inta thermostatic shower valves have been specifically designed and manufactured to meet the requirements of BS 7942: 2000 and NHS D08. The valve has been independently tested and approved as a TYPE 3 valve under the TMV3 scheme.

Technical Specification / Conditions for use TMV3 Valves

Outlet Temperature Adjustment Range	30°C to 50°C
Temperature Stability	±2°C
Maximum Hot Inlet Temperature	85°C
DO8 Working Pressure Range	0.2 to 1.0 bar : Low Pressure 1.0 to 5.0 bar : High Pressure
Min Temp Differential (Mix to Hot) for Fail-Safe	10°C
Max. Pressure Inlet Differential	5 : 1
Max. Flow Rate @ 1 bar Differential	Ø15mm 1500 l/hr (25 l/m) Ø22mm 1700 l/hr (28.3 l/m)

Operating Pressure Range	High Pressure	Low Pressure
Maximum Static Pressure	10 bar	10 bar
Flow Pressure, Hot and Cold	1 to 5 bar	0.2 to 1 bar
Hot Supply Temperature	55°C to 65°C	55°C to 65°C
Cold Supply Temperature	5°C to 20°C	5°C to 20°C

NOTE: Valves operating outside these conditions cannot be guaranteed by the Scheme to operate as Type 3 valves. See Table 1 on page 17 for Recommended Outlet Temperatures.

Approvals

TMV3 Scheme Approval Number: Details Available on Request
WRAS Scheme Approval Number: Details Available on Request

Fail Safe Function

The Inta thermostatic shower valves are designed to stop the mixed water flow in the event of either the hot or cold water supply failing when installed in accordance with these instructions. To ensure full closure of the mixed water flow the minimum temperature differential between the hot water inlet to the valve and the mixed water outlet **MUST** be at least 10°C.

Application

The Puro thermostatic shower valve has been independently tested by Buildcert Limited and certified as meeting the requirements of the NHS D08 specification under the TMV3 Scheme as being suitable for use on the following designations;

Shower HP-S

Temperature Setting

Ensure that the shower valve is commissioned under normal system conditions. The shower valve **MUST** be commissioned to suit site conditions and the desired outlet temperature set by the installer;

- i With normal supply conditions established and the hot and cold water supplies running, open the shower valve to its maximum temperature and leave running.
- ii Remove the indice, retaining screw and handle by pulling away from the tap and the temperature stop ring, see diagram on page 13.
- iii Fully open the flow control and allow the outlet temperature to stabilise.
- iv Temporarily refit the handle and using a digital thermometer it is possible to increase or reduce the mixed water outlet temperature until 38°C is re-established, by slowly rotating the handle.
- v Remove the handle and refit the temperature stop ring onto the splined section of the cartridge at the maximum temperature position.
- vi Refit the handle in the reverse order.

Installation

IMPORTANT - The following instructions must be read prior to the installation of any Inta shower valve. The installer should also be aware of their responsibility and duty of care to ensure that all aspects of the installation comply with all current regulations and legislation.

Flushing through water systems using certain chemicals may wholly or partially remove the lubricant from the internal workings of the valve, which may adversely affect its performance. We recommend that following a flushing of the system with chemicals, valves are checked for correct operation.

- 1 It is essential that before installing a Puro shower valve to ensure that the supply conditions of the system, to which the tap is intended to be fitted, are checked to confirm compliance with the parameters as quoted within the Technical Specification and conditions on which the approval is granted i.e. verify supply temperatures, supply pressures, risk assessment.
- 2 Consideration must be made for the possibility of multiple / simultaneous demands being made on the supply system whilst the basin tap is in use, all practical precautions must be made to ensure that the basin tap is not affected. Failure to make provision within the pipe sizing etc. will affect the performance of the tap.

Installation

- 3 The supply system to which the Puro shower valve is to be installed into must be thoroughly flushed and cleaned to remove any debris, which may have accumulated during the installation. Failure to remove any debris will affect the performance and the manufacturer's warranty of the product.

In areas that are subject to aggressive water, provision must be made to treat the water supply prior to the supply entering any product.

- 4 The maximum flow rate of the shower valve will only be achieved when the supply conditions are achieved as quoted within the Technical Specification, with a flow condition under 1 bar differential pressure.
- 5 These thermostatic shower valves has been designed for exposed or concealed mounting. It is essential that access to the shower valve is not be obstructed for commissioning, testing, or any future maintenance that may be required.
- 6 The hot and cold water supplies must be connected to the tap strictly in accordance with these instructions i.e. hot water supply to the hot port of the shower valve.
- 7 In a situation where one or both of the water supplies are excessive, it is possible to fit a pressure reducing valve or a flow regulator to reduce the pressure(s) to within the limits as quoted previously.
- 8 Any thermostatic shower valve must be fitted with a back flow prevention device, such as check valves to prevent the cross contamination of supplies.
- 9 Independent filters/check valves and isolation valves must be fitted in conjunction with the Puro shower valve, as close as practically possible to the water supply inlets.

The Puro shower valve has an integral filters and check valves in the inlet connection on the hot and cold supplies.
- 10 It is essential that the Puro shower valve should not be installed in situations where there is a possibility of the shower valve being deprived of water or where demands for water are greater than the actual stored supplies.
- 11 To ensure that the performance levels of the Puro shower valve is maintained (in the event of cold water failure), the temperature of the hot water supply at the point of entry to the valves must be a minimum of 10°C above the commissioned mixed water discharge temperature.
- 12 The Puro shower valve must not be subject to any extreme temperature variations either during the installation or under normal operating conditions.

Commissioning

IMPORTANT - The following instructions must be read and understood prior to commissioning the Puro thermostatic shower valve. If under any circumstances there are aspects to the installation / system which do not comply with the specification laid down, the shower **MUST NOT** be put into operation until the system / installation complies with our specification. However if all these conditions are met, proceed to set the temperature as follows;

- 1 Ensure that the system is thoroughly cleaned and free from any debris prior to the commissioning the Puro thermostatic shower valve.

Commissioning

- 2 Commissioning the temperatures must be carried out using a suitably calibrated thermometer preferably a digital thermometer.
- 3 In the absence of other temperatures being specified, we recommend the outlet temperature quoted in Table 1 are used.

Table 1

Application	Recommended Set Mixed Water Temp.
Shower	41°C

- 4 Each shower valve must be commissioned taking into consideration any fluctuations, which may occur within the system due to simultaneous demands. It is advisable that any outlets which are connected to the same supply as the shower valve are opened during the setting of the mixed water temperature. During commissioning it is advisable to ensure that the water temperatures are established before any attempt to commission.
- 5 Once the supply temperatures are stable and the normal operating conditions are established, the shower valve can be commissioned. The temperature setting can be adjusted following the procedure described earlier in the Temperature Setting section.

We suggest that the following sequence is followed when commissioning the valve:

- 5.1 Set the mixed water temperature to the required temperature.
- 5.2 Measure and record the temperature of the hot and cold water supplies at the connection to the tap.
- 5.3 Measure and record the temperature of the water discharging from the basin tap.
- 5.4 Isolate the cold water supply to the tap and monitor the mixed water temperature.
- 5.5 Measure and record the maximum mixed water temperature and the final temperature. The final temperature found during the test should not exceed the value quoted in Table 2.
- 5.6 Record all the equipment used during the commissioning.

Table 2

Application	Maximum Set Mixed Water Temp.
Shower	43°C

- 6 Ensure that the application, in which the basin tap will be used, is appropriate for the approved designation. The above information must be recorded and updated on every occasion when any work is carried out on the basin tap.

Maintenance

To ensure the Puro thermostatic shower valve maintains a high level of protection, we advise the following in service testing is conducted (the same equipment used to commission the basin tap initially must be used in the following tasks).

- 1 After a period of between 6 and 8 weeks from commissioning carry out the following;
 - 1.1 Record the temperature of the hot and cold water supplies.
 - 1.2 Record the temperature of the mixed water from the shower valve.
- 2 If the mixed water temperature has changed significantly from the previous test results (e.g. $>1^{\circ}\text{K}$), record the change and before resetting the mixed water temperature check that:
 - 2.1 All the strainers are clean.
 - 2.2 All the check valves are in good working order.
 - 2.3 The isolation valves are fully open.
- 3 If the mixed water temperatures are acceptable, carry out the following:
 - 3.1 Record the temperature of the hot and cold water supplies.
 - 3.2 Record the temperature of the mixed water from the basin tap.
 - 3.3 Isolate the cold water supply to the mixing valve and monitor the mixed water temperature.
 - 3.4 Record the maximum temperature achieved as a result of (3.3) and the final temperature (the final temperature should not exceed the values quoted in table 2)
 - 3.6 Record the equipment used during these tests.
- 4 If the mixed water temperature is greater than the values quoted in table 2 or the maximum temperature exceeds the corresponding values from previous test results by more than 2°K , the shower valve must be serviced.
- 5 After a period of between 12 to 15 weeks from commissioning, carry out the sequence of tests as described in Maintenance sections 1, 2, 3 and 4.
- 6 Dependant upon the results obtained from the first two series of tests; there are a number of possible outcomes:
 - 6.1 If no significant change in the mixed water temperatures (e.g. $\leq 1^{\circ}\text{K}$) is recorded between commissioning and Maintenance sections 1 or between commissioning and Maintenance sections 5, the next in service testing should be carried out at a period of 24 to 28 weeks after initial commissioning.
 - 6.2 If a small change (e.g. 1 to 2°K) in the mixed water temperature is recorded in only one of these periods, necessitating adjustment of the mixed water temperature, then the next in service can be deferred to 24 to 28 weeks after commissioning.
 - 6.3 If small changes (e.g. 1 to 2°K) in the mixed water temperature are recorded in both of these periods, necessitating adjustment of the mixed water temperature, then the next in service test can be deferred to 18 to 21 weeks after commissioning.

Maintenance

- 6.4 If significant changes (e.g. $> 2^{\circ}\text{K}$) in the mixed water temperature are recorded in both of these periods necessitating service work, then the next in service test should be carried out at 18 to 21 weeks after commissioning.
- 7 The general principle to be observed after the first 2 or 3 in-service tests is that the intervals for future tests should be set to those which previous tests have shown can be achieved with no more than a small change in mixed water temperature.
- 8 In all areas periodic maintenance of the valve and associated fittings i.e. strainers, check valves will ensure optimum performance levels are maintained.

Spares

A full range of spares are available for this product from Inta.

PLEASE NOTE: Only genuine spares should be used.

Please leave this Manual for the User

To activate your product warranty please visit

www.intatec.co.uk

and click on Product Registration

Intatec Ltd

Airfield Industrial Estate
Hixon
Staffordshire
ST18 0PF

Tel: **01889 272 180**

Fax: **01889 272 181**

email: **sales@intatec.co.uk**

web: **www.intatec.co.uk**