

inta

Intamix Pro

Thermostatic Mixing Valves

Installation and Maintenance Instructions

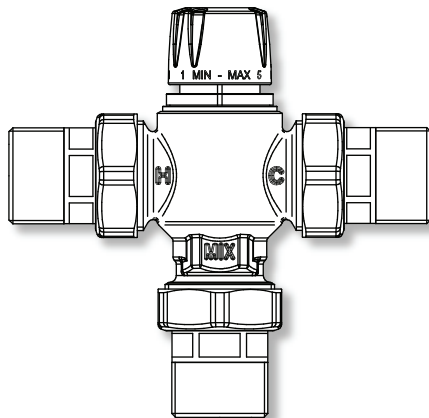

inta

Intatec Ltd

Airfield Industrial Estate

Hixon

Staffordshire

ST18 0PF

In this procedure document we have endeavoured to make the information as accurate as possible.

We cannot accept any responsibility should it be found that in any respect the information is inaccurate or incomplete or becomes so as a result of further developments or otherwise.

Tel: **01889 272 180**

Fax: **01889 272 181**

email: **sales@intatec.co.uk**

web: **www.intatec.co.uk**

Introduction

A thermostatic mixing valve (TMV) is used in domestic hot water systems.

It's function is to maintain the temperature of the mixed water, supplied to the user, constant at the set value when there are variations in the supply pressure and temperature of the incoming hot and cold water or in the flow rate.

The Intamix Pro TMV has been specifically designed for applications requiring a high volume of water at multiple outlets, such as shower blocks and central mixing.

Systems of this nature require precise, stable temperature control, especially when there are variations in the flow rates drawn off by the users.

It is recommended, especially in hard water areas, that a water softener such as the ActivFlo or ActivFlo lite be fitted to reduce the risk of calcium deposits forming.

Products

Intamix Pro ½" with male union connections MxMxM	60001CP
Intamix Pro ¾" with male union connections MxMxM	60003CP
Intamix Pro 1" with male union connections MxMxM	60004CP
Intamix Pro 1¼ with male union connections MxMxM	60005CP
Intamix Pro 1½" with male union connections MxMxM	60006CP
Intamix Pro 2" with male union connections MxMxM	60023CP

The 60001CP, 60003CP, 60004CP and 60005CP are supplied with integral check valves and filters

Technical Data

Temperature range:	30 to 65 °C
Max. working pressure:	10 bar - Static
Max. working pressure:	5 bar - Dynamic
Min. working pressure:	0.2 bar
Max. inlet temperature:	90 °C
Max. inlet ratio (H/C or C/H):	2:1
Accuracy:	±2%

Dimensions

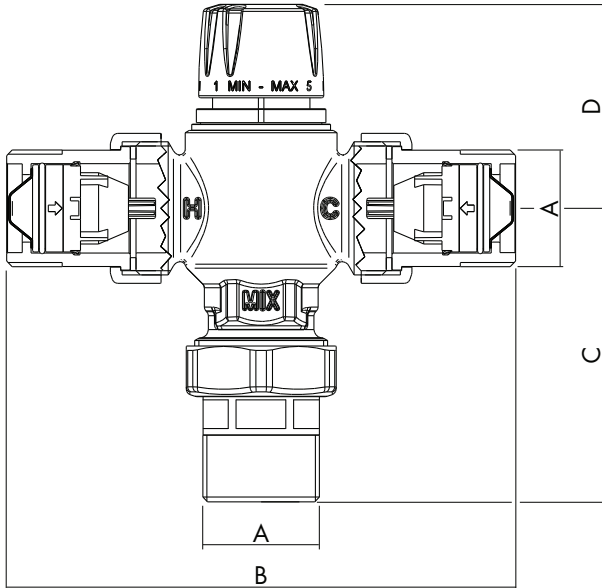

Product Code	A	B	C	D
60001CP	G½	108	67	55
60003CP	G¾	118	72	55
60004CP	G1	165	96	79
60005CP	G1¼	183	105	79
60006CP	G1½	217	125.5	100
60023CP	G2	238	138.5	100

Construction

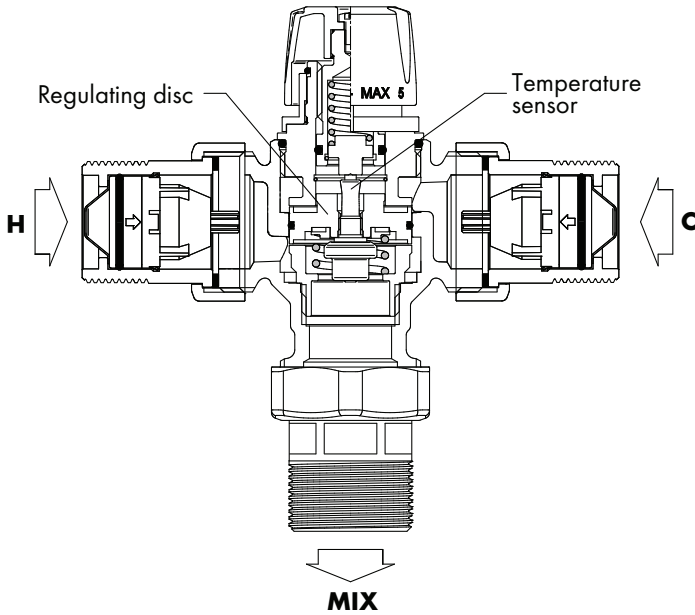

Flow Rate Chart

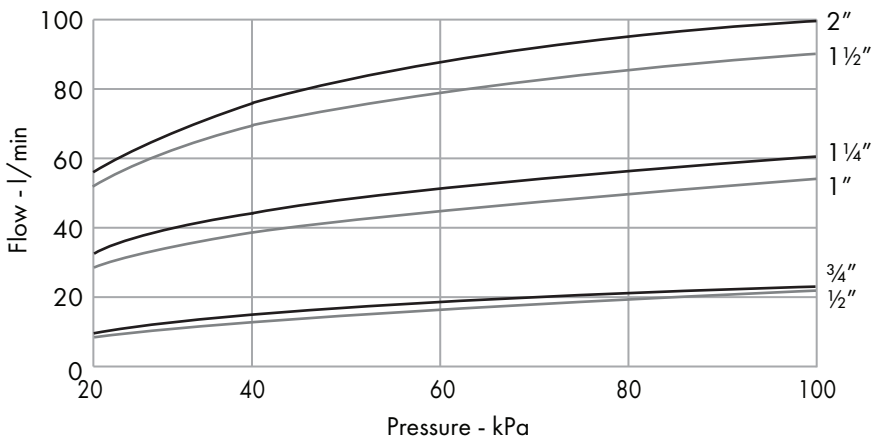

Application

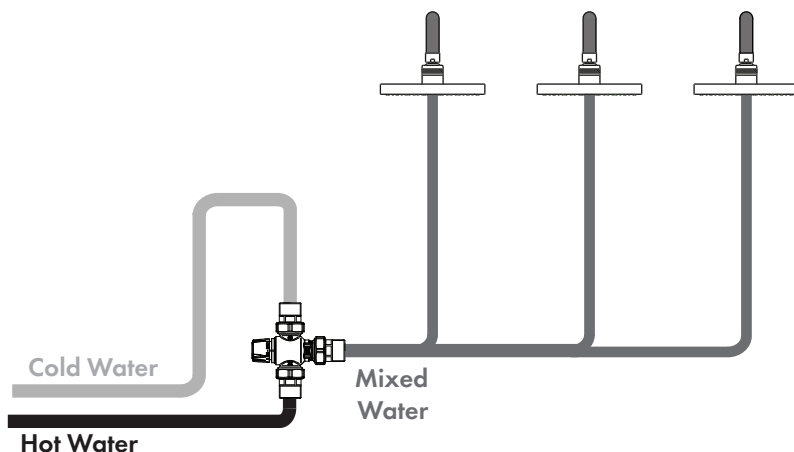

Installation

If the thermostatic mixing valve is not installed, commissioned and maintained properly, according to the instructions contained in this manual, it may not operate correctly and may endanger the user.

Before installation the system must be checked to ensure that its operating conditions are within the range of the valve; eg the supply temperatures, pressures and flow rates.

Systems must be flushed to remove any dirt or debris, which may have accumulated during installation, which may affect its performance and the manufacturer's product guarantee.

Failure to remove dirt or debris may affect the performance and the manufacturer's product guarantee.

The installation of filters, of appropriate capacity, at the inlet from the mains supply is always advisable.

In the case of highly aggressive water, arrangements must be made to treat the water before it enters the thermostatic mixing valve, in accordance with current legislation.

Intamix Pro TMV must be installed strictly in accordance with the Water Supply (Water Fitting) Regulations 1999, any local authority regulations and the diagrams in this manual.

They can be installed in any orientation, either vertically or horizontally.

The following are shown on the mixer body:

- ~ hot water inlet, denoted by the letter '**H**'.
- ~ cold water inlet, denoted by the letter '**C**'.
- ~ mixed water outlet, denoted by the letters '**MIX**'.

Installation Continued

It is essential that access to the valve is totally unobstructed for any maintenance which may be required or to the connections.

The pipework to or from the valve must not be used to support the valve unless adequately supported.

Commissioning

After installation, the valve must be tested and commissioned in accordance with the instructions given below, taking into account current applicable standards and Codes of Practice.

1. Ensure that the system is clean and free from any dirt or debris before commissioning.
2. It is recommended that the temperature is set using a suitable calibrated digital thermometer. The valve is commissioned by measuring the temperature of the mixed water emerging at the point of use.
3. The maximum discharge temperature from the valve must be set to take account of fluctuations due to simultaneous use.

Allow conditions to stabilise before measuring the temperature and commissioning

4. Adjust the temperature using the adjusting knob on the valve.

Setting the Temperature

The temperature is set to the required value by means of the adjusting knob with the graduated scale located at the top of the valve.

1. Using a suitably sized screw driver unscrew the knob retaining screw.
2. Note the position of the lug on the body and the corresponding recess inside the knob.
3. Temporarily refit the knob onto the splined section of the stem and rotate the stem to alter the mixed water temperature.

To increase the temperature, rotate the spindle anti-clockwise.

To decrease the temperature, rotate the spindle clockwise.

4. Allow the outlet temperature to stabilize for 60 seconds and once again take a temperature reading.

Repeat the procedure until the desired temperature has been reached.

5. Check the circulating water temperature is stable.

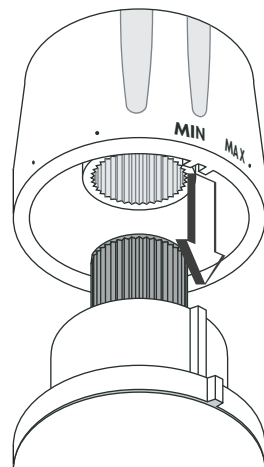

Preset Locking

Position the adjusting knob to the temperature required.

Unscrew the retaining screw.

Remove the knob by pulling away from the valve and reposition on the splined shaft so that the internal slot locates on the position indicator on the knob frame.

Re fit and tighten the retaining screw.

Maintenance

In service, tests should be carried out regularly to monitor the TMV's performance, as deterioration could indicate that the valve and/or the system require maintenance.

If, during these tests, the temperature of the mixed water has changed significantly when compared with the previous test, the details given in the Installation and Commissioning sections should be checked and maintenance carried out.

The following should be checked regularly to ensure that the optimum performance levels of the valve are maintained.

Every 12 months or more often if necessary.

1. Check and clean the system filters.
2. Check that any non-return valves positioned upstream of the TMV are operating correctly and free from debris.
3. Limescale can be removed from internal components by immersion in a suitable de-scaling fluid.
4. When the components have been checked and maintained, the mixed water outlet temperature should be checked using a thermometer following the procedure detailed in the Commissioning section.

Problem Solving

The following details are supplied for on site queries, should you require any further assistance our Technical Department can be contacted directly on 01889 272 199.

1 Hot water at cold outlet

- i. Operation of the in line check valves is hindered, check the valve is seated correctly.
- ii. Check Valves not fitted.
- iii. Unbalanced hot/cold supply pressure.

2 Fluctuating mixed water temperature

- i. Erratic supply temperatures at the inlets of the valve.
- ii. Starvation of the water supplied at the inlets of the valve.
- iii. Incorrect commissioning of the valve.

Problem Solving Continued

3 Erratic flow

- i. Insufficient water supplies.
- ii. Fluctuations in the supply pressures/temperatures.
- iii. Adverse effect created by other draw off points on the system.

4 No flow/reduced flow from valve

- i. In line filters are blocked.
- ii. Insufficient supply pressure.
- iii. Debris obstructing valve operation.
- iv. Valve requires servicing.

Please leave this Manual for the User

To activate your product warranty please visit

www.intatec.co.uk

and click on Product Registration

inta

Intatec Ltd

Airfield Industrial Estate
Hixon
Staffordshire
ST18 0PF

Tel: **01889 272 180**

Fax: **01889 272 181**

email: **sales@intatec.co.uk**

web: **www.intatec.co.uk**