

# inta

---

## *Thermal Balancing Valve*

### **60040CP & 60041CP**

#### ***Installation and Maintenance Instructions***

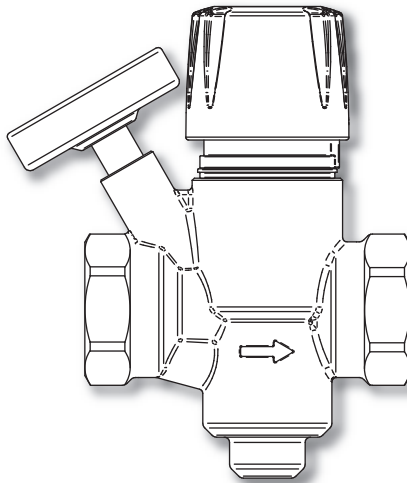

# inta

**Intatec Ltd**

Airfield Industrial Estate  
Hixon  
Staffordshire  
ST18 0PF

In this procedure document we have endeavoured to make the information as accurate as possible.

We cannot accept any responsibility should it be found that in any respect the information is inaccurate or incomplete or becomes so as a result of further developments or otherwise.

Tel: **01889 272 180**

Fax: **01889 272 181**

email: **sales@intatec.co.uk**

web: **www.intatec.co.uk**

## **Introduction**

The Inta thermal balancing is used in domestic hot water distribution circuits to ensure that all sections are kept at the correct temperature and to balance the re-circulation network in order to avoid non-uniform temperature distribution.

The thermostatic regulator, installed on each branch of the recirculation circuit, automatically maintains the set temperature, granting the benefits of an anti-legionella treatment.

This device regulates the flow from the hot water calorifier and it is equipped with an adjusting knob to set the temperature and a temperature gauge in order to check any variance of the temperature.

## **Products**

½" Thermal Balancing Valve	60040CP
¾" Thermal Balancing Valve	60041CP

## **Technical Specification**

The conditions under which the valves will be operating must comply with the following;

Fluid:	Water
Accuracy:	±2 °C
Max. static pressure:	10 bar
Max. dynamic pressure:	5 bar
Max. Inlet temperature:	90 °C
Temperature setting range:	1 to 5
Temperature adjustment range:	40 to 60 °C
Flow rate:	3 l/min
Kv:	1.5

## **Materials of Construction**

Valve body:	DZR - BS EN 12165 CW625N
Springs:	Stainless steel
Seals:	EPDM Peroxide
Internal components:	DZR- BS EN 12165 CW625N Polymer - 20% reinforced Polymer - high strength

## Dimensions

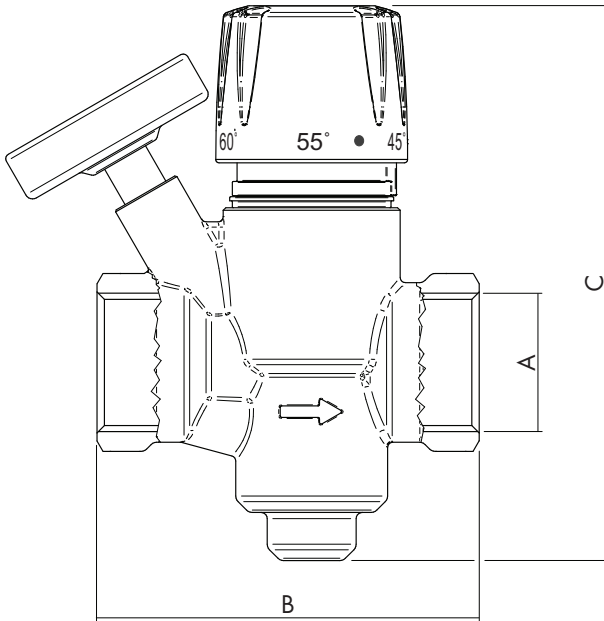

Code	A	B	C
60040CP	G $\frac{1}{2}$ "	70	113
60041CP	G $\frac{3}{4}$ "	73	113

## Installation

To achieve equal distribution of hot water the valve has to reduce the flow in each branch of the system, regulating the flow as soon as the temperature reaches the set value.

The thermostatic balance valve can be installed to serve an individual outlet or to control a group of terminal fittings in branch such as a public wash room.

The valve regulates the flow from the hot water calorifier and it is equipped with an adjusting knob to set the temperature and a thermometer in order to check any variance of the temperature.

### Single outlet

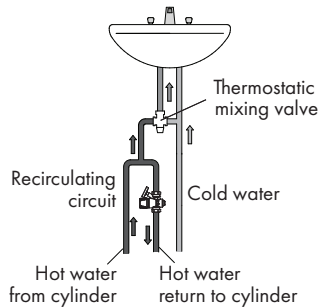

### Group of terminal fittings

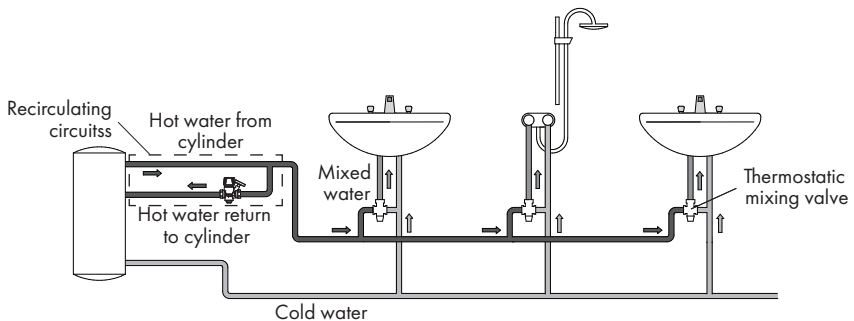

---

## **Installation**

Before fitting the thermostatic balancing valve, the pipes must be thoroughly flushed to remove any debris or particles which will reduce its performance.

It is recommended to always install strainers of sufficient capacity at the inlet from the water main.

The valve should be installed on the return, in any position by respecting the flow direction indicated by the arrow on the valve body.

The recirculation circuits are generally sized according to the flow rate required for each branch, based on the allowed heat dispersion and the corresponding decrease in temperature along the pipe.

Generally, the maximum allowable temperature drop between the point of departure from the calorifier and the point of return is 5 °C and considering that the sum of the flows has to be higher than the minimum flow rate required by the valve.

## Presetting

The valve can be preset using the adjusting knob by turning it until the required temperature corresponds with the indicator on the frame.

The valve can be locked at the preset temperature by:

- Unscrewing the retaining screw.
- Remove the knob by pulling away from the valve and repositioning on the splined shaft so that the internal slot locates on the position indicator on the frame.
- Refit and tighten the retaining screw.

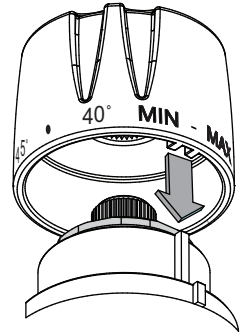

## Sizing Chart

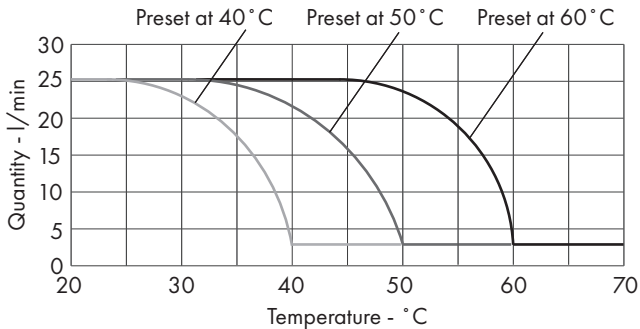

**Notes:**

# inta

---

## **Please leave this Manual for the User**

To activate your product warranty please visit  
**[www.intatec.co.uk](http://www.intatec.co.uk)**  
and click on Product Registration

# inta

**Intatec Ltd**

Airfield Industrial Estate  
Hixon  
Staffordshire  
ST18 0PF

Tel: **01889 272 180**

Fax: **01889 272 181**

email: **[sales@intatec.co.uk](mailto:sales@intatec.co.uk)**

web: **[www.intatec.co.uk](http://www.intatec.co.uk)**