

Infra Red

Thermostatic Wall Mixer

HTMWMBCP, HTMWMMCP, HTMWMBRS & HTMWMMRS

Installation and Maintenance Instructions

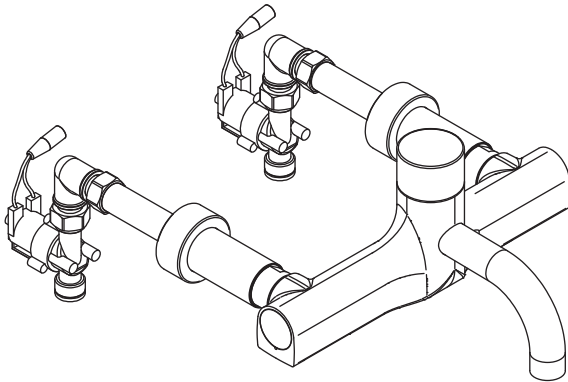

In this procedure document we have endeavoured to make the information as accurate as possible.

We cannot accept any responsibility should it be found that in any respect the information is inaccurate or incomplete or becomes so as a result of further developments or otherwise.

Intatec Ltd

Airfield Industrial Estate
Hixon
Staffordshire
ST18 0PF

Tel: **01889 272 180**

Fax: **01889 272 181**

email: **sales@intatec.co.uk**

web: **www.intatec.co.uk**

Contents

Thank you for choosing the Inta infra red thermostatic wall mixer.

Subject	Page
Introduction	2
Technical Data	2
Components - Fixed Spout	3
Components - Removable Spout	4
Dimensions	6
Installation	6
Battery Replacement	7
Installation Connections	8
Operation	8
Trouble Shooting	9
Re-calibration	10
Aftercare	11
Removing Spout and Disinfection	11
System Flushing Procedure	13
Sterilization Process	14
TMV3 Installation Instructions	16
Guarantee	21

Introduction

This installation guide has been produced for the Infra red wall mounted thermostatic control mixer. These instructions cover the installation, operation and maintenance. Please read the enclosed instructions before commencing the installation of this product, please note;

We recommend that the installation is carried out by an approved installer.

The installation must be carried out strictly in accordance with the Water Supply (Water Fitting) Regulations 1999 and any local authority regulations.

If in doubt we recommend that you contact WRAS - Water Regulations Advisory Scheme on Tel: 0333 207 9030, your local water authority - details available on the WRAS website or the Chartered Institute of Plumbing and Heating Engineers on Tel: 01708 472 791.

All products MUST be re-commissioned to suit site conditions to ensure optimum performance levels of the product are obtained.

Check Content

Before commencing remove all components from packaging and check each component with the contents list.

Ensure all parts are present, before discarding any packaging. If any parts are missing, do not attempt to install your control mixer until the missing parts have been obtained.

Product Range

HTMWMBCP - HTM safe touch infra red thermostatic wall mounted tap battery operated.

HTMWMMCP - HTM safe touch infra red thermostatic wall mounted tap mains operated.

HTMWMBRS - HTM safe touch infra red thermostatic wall mounted tap battery operated with removable spout.

HTMWMMRS - HTM safe touch infra red thermostatic wall mounted tap mains operated with removable spout.

Technical Data

This Inta thermostatic mixer is suitable for installations on all types of plumbing systems, including gravity supplies, fully pumped, modulating combination boiler, unvented water heater and unbalanced supplies i.e. Cold Mains & Tank Fed Hot.

Max Dynamic Pressure	5 bar	Temperature Stability	± 2°C
Max Static Pressure	12 bar	Min Temp Differential to	
Max Inlet Temperature	85°C	ensure fail-safe between hot	
Pre Set Factory Temp Setting	41°C	cold supplies	10°C
Max Unbalanced Pressure Ratio	5:1	Auto Flush Feature after	
Min Operating Pressure	1.0 bar	24 hours of none usage	
Min Inlet Temperature	10°C		

Preparation for Installation

Before starting the installation, ensure that the site conditions are suitable - see Technical Data.

The tap is supplied for wall mounting as shown.

Flush the water supply pipes thoroughly prior to installation - see page 13. Do not allow debris, PTFE tape or any metal particles to enter the mixer.

Components - Fixed Spout

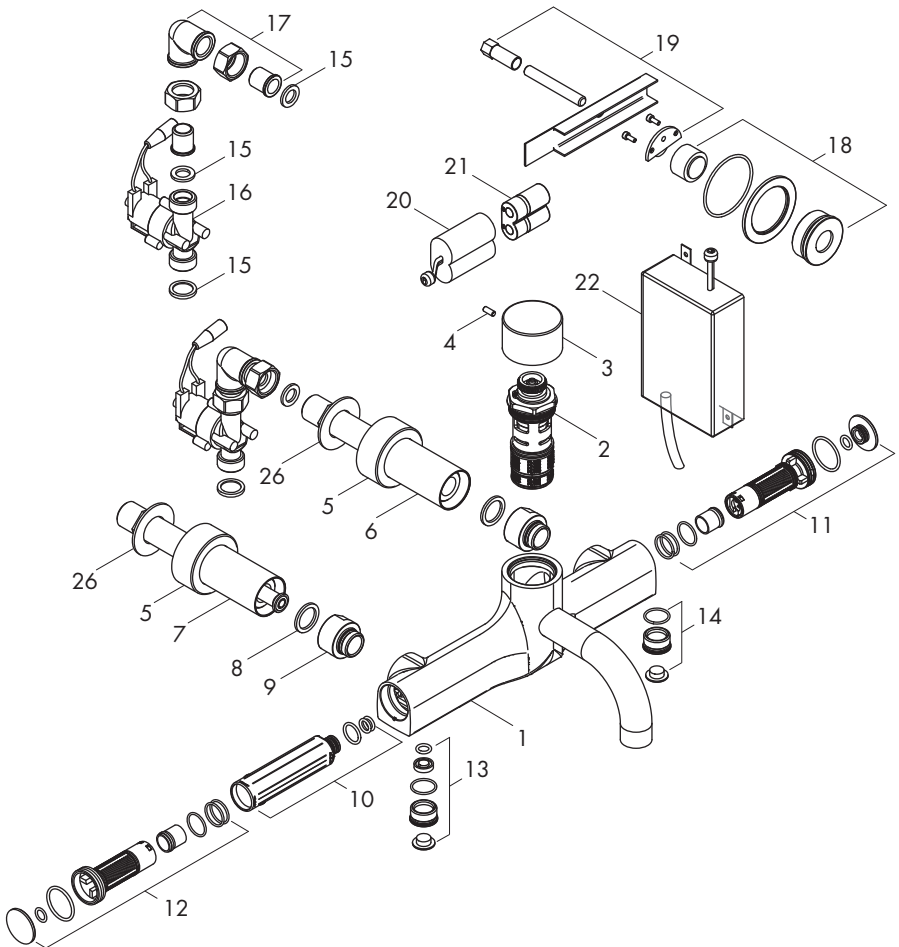

Components - Removable Spout

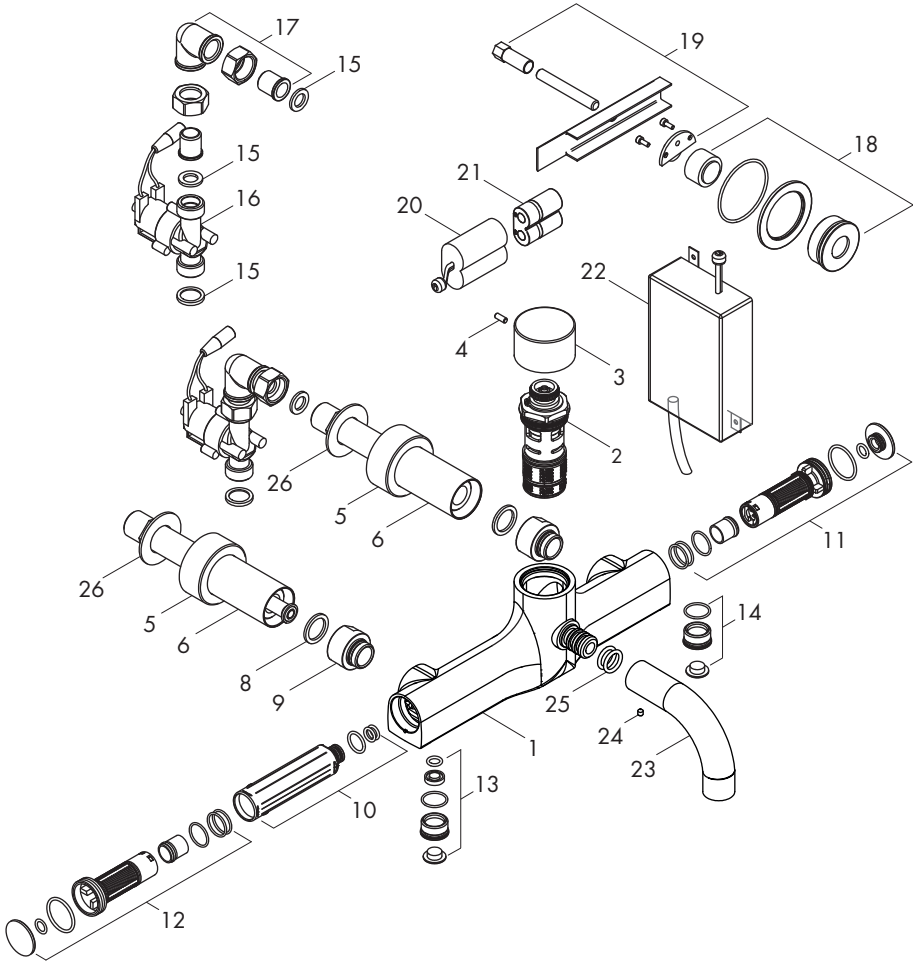

Components

Item	Description	Item	Description
1	Body inc. Outlet Diffuser	12	Hot Water Inlet Assembly including 5 l/m flow regulator
2	Thermostatic Cartridge		
3	Cover	13	Hot Water Port Blanking Assembly
4	Cover Retaining Screw	14	Cold Water Port Blanking Assembly
5	Concealing Plate	15	Sealing Washer
6	Cold Water Inlet Tail Assembly	16	Solenoid Valve
7	Hot Water Inlet Tail Assembly	17	Elbow Assembly
8	Sealing Washer	18	Infra Red Sensor
9	Swivel Nut	19	Mounting Bracket
10	Hot Water Insulator	20	Battery Box
11	Cold Water Inlet Assembly including 5 l/m flow regulator	21	Battery
		22	Transformer
		26	Backnut

Components - Removable Spout

Item	Description	Item	Description
1	Body	24	Spout Retaining Screw
23	Spout	25	'O' Ring

Dimensions

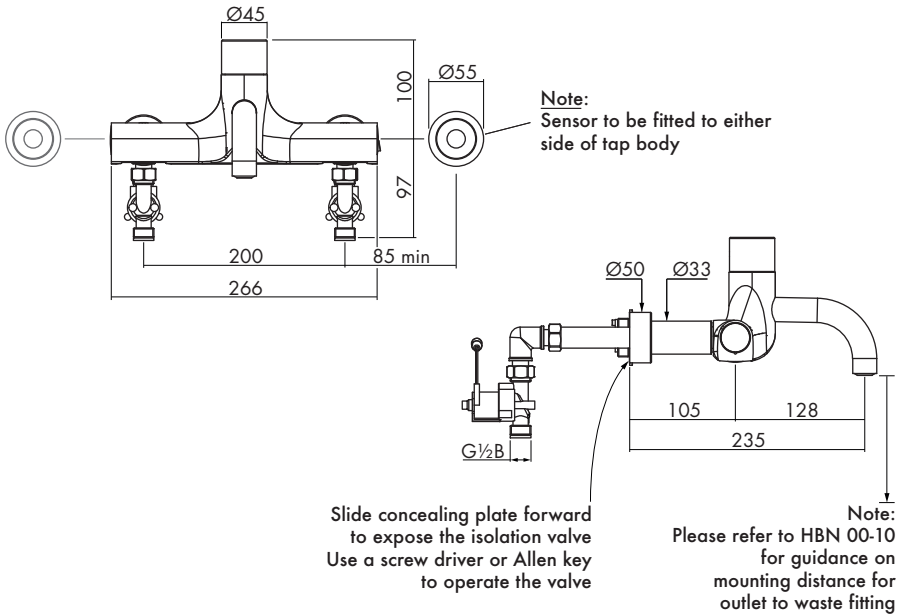

Installation

- Ensure that the location of the solenoid valve and battery will be in an easily accessible position for any future servicing.
- The two union joints on the elbows (17) can be used to position the solenoid valves above or below the inlet to the mixer, ensure the flow through the solenoid valves is in the correct direction.
- The tap is supplied as shown in the Components except that the thermostatic cartridge (2) and swivel nut connectors (9) are fitted into the body.
- Fit the concealing plates (5) onto the tailpieces (6) & (7).
- Screw the tailpiece (6) into the cold water inlet of the tap, right hand side when facing the tap.

ATTENTION: The hot water inlet connection tail can be identified by the brass insulator pipe that protrudes past the connecting thread. Care must be taken to ensure the Hot Water Inlet Tail Assembly is connected securely into the hot water inlet of the tap body.

- Screw the tailpiece (7) into the hot water inlet of the tap, left hand side when facing the tap.

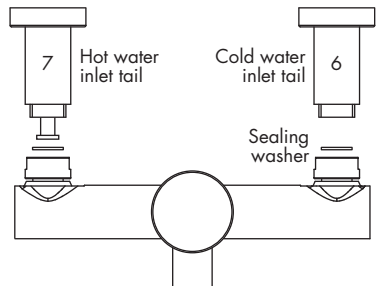

Installation

- Fit tap assembly to the mounting panel, using the back nuts and slide the concealing plates to the panel.
- Connect the supply pipes to the tap, cold on the right, hot on the left.
- Fit the cover (3) to the tap using the grub screw (4) provided.
- Assemble the elbow components (17) to solenoid valves and assemble to the inlet tails (6) and (7) ensuring a water tight joint. The solenoid valve bodies should be secured to the tap inlets.
- Please ensure that the hydraulic installation is completed and that all isolation valves are in the open position.
- Install the sensor a safe distance from the body of the tap, as illustrated on page 6, ensuring that the electric cables supplied are long enough to connect the sensor (18) to the battery box (20) or transformer (22). Using double sided tape (not supplied) stick the power supply box to the wall.
- Ensure that the sensor cannot be affected by any external sources such as a mirror which may create nuisance in the operation of the product.
- Connect the sensor to the solenoid valves and the battery or transformer. The sensor calibrates itself automatically and the tap is ready to work. Within a range of 3 to 8 cm the sensor detects objects and opens the solenoid valves for a max of 60 sec.
- If the users wishes to stop the water flow before, a simple hand wave in the 3 to 8cm distance is enough to give the stop order.
- Care should be taken that the maximum panel thickness does not exceed 33mm.
- The battery pack can be secured to the sensor bracket if required.

Battery Replacement

When the battery is ready for changing the LED on the sensor will flash continuously and the mixer continues to operate normally.

When the LED remains illuminated the battery is exhausted and must be replaced.

1. Turn off the water supply to the hot and cold connections of the mixer.
2. Pull apart the two halves of the connector to disconnect the battery.
3. Remove the battery from the battery box and replace with a new one of the same type - model CRP2 - 6 Volt.
4. Re-connect the two parts of connector to re-connect the battery.
5. Turn on the water supplies and cover the sensor window with a finger until the water turns off automatically
6. Remove your finger and the mixer enters the auto programme sequence.
7. The mixer is now ready for use.

Installation Connections

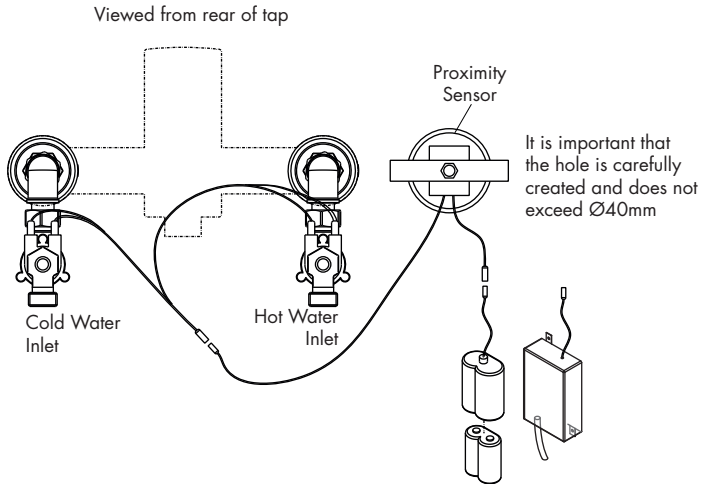

Operation

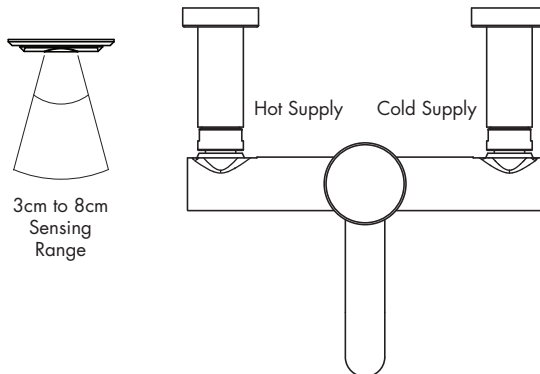

As the sensor is activated the flow of water will commence, the mixer is factory set to deliver water at a pre-set maximum temperature of 41°C .

Trouble Shooting

Fault

Mixed water temperature is not hot enough.

Diagnosis

Ensure the hot water supply is at a constant temperature above 60°C.

Re-calibrate as per page 10.

Check for airlocks in the pipework.

The water goes cold during operation.

Insufficient stored hot water supply.

Ensure that the boiler is still firing for combi boilers.

Adjust the boiler control to a minimum setting of 65°C not necessarily the best flow rate.

Temperature is too hot or when set to hot water runs cold.

Check the commissioned maximum temperature of the valve. Check connections to the mixer are not reversed.

Flow of water through the valve is low.

Check the filters are clean and supply pressure is above 1 bar.

No flow of water.

Ensure the mixer has not fail-safed, and check that there is water flow to the mixer and the service valves are not closed - see exploded drawing.

Re-Calibration

The factory setting at 41°C can be altered to suit site conditions.

Warning: Care must be taken when altering the setting as **incorrect calibration can cause injury.**

- Remove the grub screw (4) and lift the cartridge cover off (3).
- Re-calibrate by removing the temperature stop rings from the cartridge and set the mixed water to the required temperature.
- Once the required temperature is achieved replace the two temperature stop rings on the splined spindle of the cartridge as shown. These two rings are used to prevent the temperature of the cartridge from being altered whilst in use. The stop rings should be locked at either end of the operating cycle and will form a physical stop to prevent the cartridge turning (see below)
- Refit the cartridge cover (3) and grub screw (4).
- Recheck the calibrated temperature

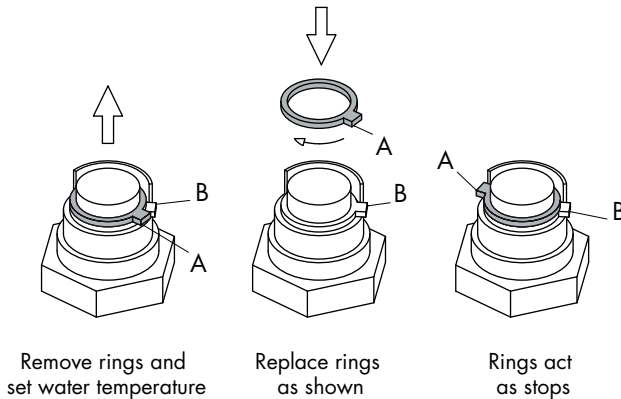

Aftercare

- With all highly polished items, care should be taken not to damage any of the external surfaces.
- We recommend that to ensure the physical appearance of the product and component parts that it is periodically cleaned with a soft damp cloth and a mild detergent. The use of abrasive or solvent cleaners will damage the finish of the product.
- Care should be taken when cleaning the sensor eye not to damage it by using abrasive cleaners.
- We recommend periodically that the flow straightener is cleaned using a suitable scaling solvent. Check first it does not affect the plated surface.
- The internal bore of the flow straightener must be periodically wiped using a damp cloth.
- We recommend that this fitting is serviced at least once a year.
- Only use genuine spare parts, the full list is available on request by ringing the Technical Helpline number on the back page.

Removing Spout

The HTMWMBRS and HTMWMMRS wall mounted taps have a removable spout to assist with cleaning, disinfection by immersion or sterilisation in an autoclave.

Inta recommend that a replacement spout is available as the tap should not be left without a spout (HTMSP16XX).

Cleaning, disinfection and sterilisation is only necessary if there is evidence of solid deposits around the outlet from the tap or a minimum of once per year.

- Ensure the isolation valve in both supplies to tap are in the closed position to prevent water flow and potential flooding.

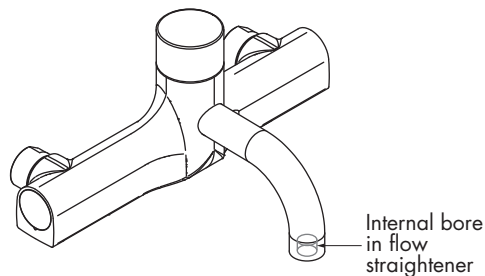

Removing Spout

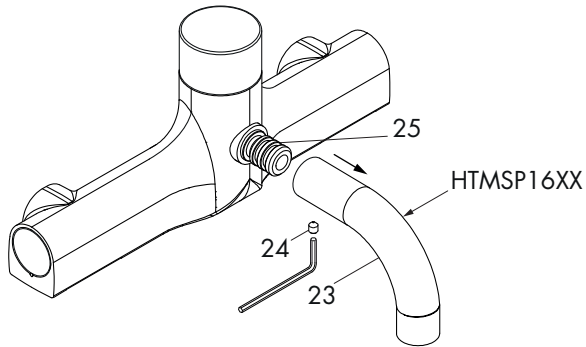

- Using a suitably sized Allen key unscrew the grub screw (24) located beneath the spout. The grub screw must be removed completely to ensure the 'O' rings are not damaged when the spout is pulled away.
- Pull the spout (23) away from the body of the tap, care should be taken to prevent damage to the chrome finish of the spout.
- Check the condition of the two 'O' rings (25) on the spigot of the tap body, if damaged they must be replaced.

Once the spout with integral flow straightener has been removed disinfection or sterilisation can commence.

- The spout can be sterilised in an Autoclave following standard sterilisation procedures.
- The spout after disinfection and sterilisation should be stored in such a manner that they will not become infected or dirty before refitting.

Refitting Spout

- When refitting the spout lubricate the two 'O' rings with a suitable lubricant to ease re-assembly.
- Fit and re-tighten the grub screw (24).
- Open the isolation valve in both supplies to the tap.
- Only use genuine spare parts, the full list is available on request by ringing the Technical Helpline number on the back page.

System Flushing Procedure

The water system must be thoroughly flushed before attempting to commission or operate this tap to ensure all pipework is clean and free from any debris. This system flushing procedure allows the process to be efficiently conducted with the tap installed. Failure to carry out effective system flushing before commissioning or operating this product could damage or limit the performance of the product and invalidate the product guarantee.

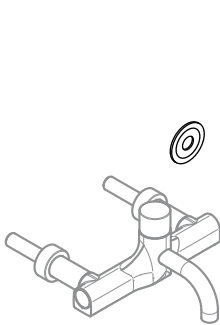

1 - Water must not pass through the tap before completing system flushing

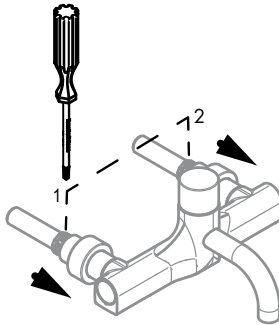

2 - Ensure both isolation valves are in the closed position

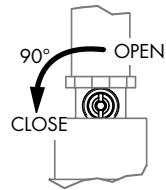

2A - Turn to closed position

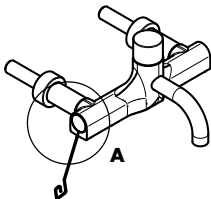

3 - Remove end cover from the hot supply end of the tap

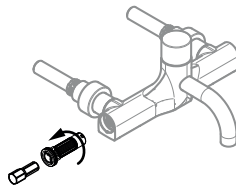

4 - Carefully remove check valve housing using the extraction tool (HTM5P20XX) and rotating anti-clockwise

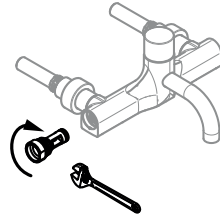

5 - Screw in connector plug using suitably sized spanner

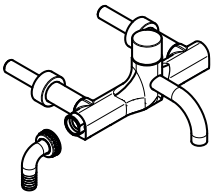

6 - Attach hose connector

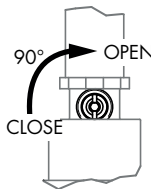

7 - Open the isolating ball valve to allow water to flush the hot supply system and hot side of the tap

Wave hand in front of sensor to start water

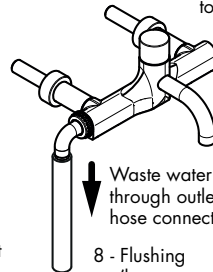

Waste water flushed through outlet with hose connected

8 - Flushing (hose not supplied)

System Flushing Procedure

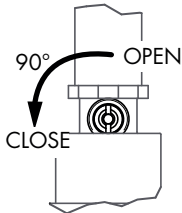

9 - Close the isolating ball valve on the hot supply

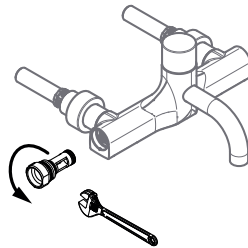

10 - Unscrew the connector plug using a suitably sized spanner and refit the check valve housing and end cover

11 - Repeat the procedure for the cold inlet side.

Sterilization Process

NOTE: Not a replacement for chlorination

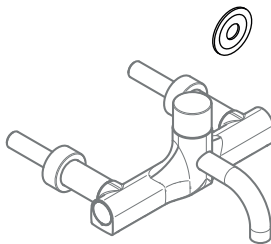

1 - Start with or without water flow

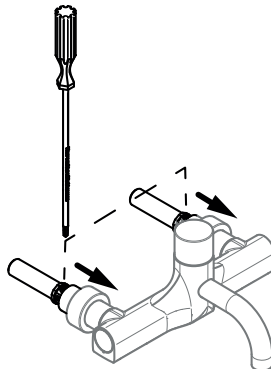

2 - Ensure both isolation valves are in the closed position

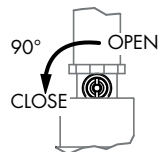

2A - Turn to the closed position

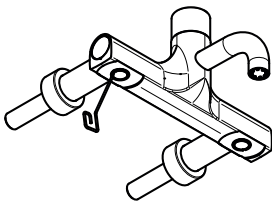

3 - Remove the cover from each inlet of the tap

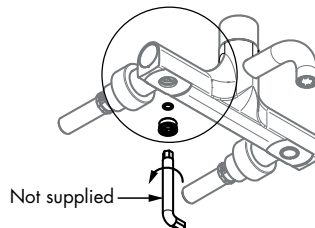

4 - Remove hot and cold inlet plugs using a 10mm Allen key

Sterilization Process

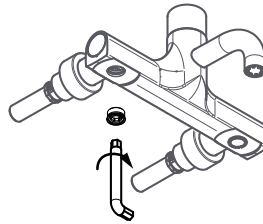
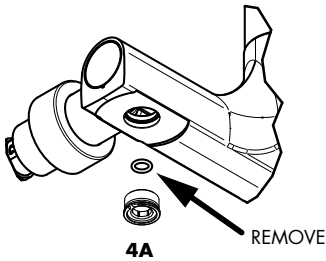

5 - Fit the cold inlet plug into the hot position and the hot into the cold position

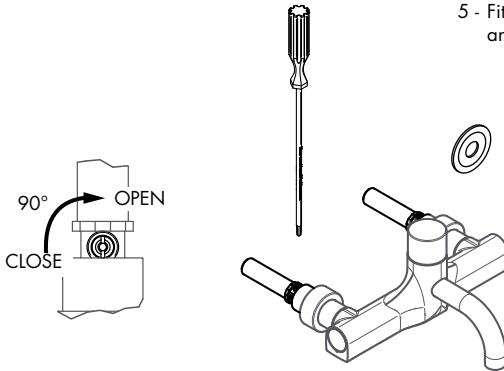

6 - Open the hot inlet isolating ball valve

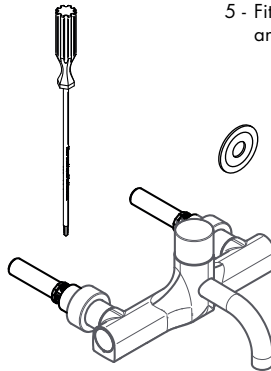

7 - Open the isolating ball valve on the hot supply to start sterilization procedure

Wave hand in front of sensor to start water flow. See table below for times needed

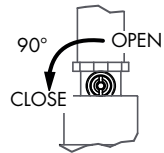

8 - Close the isolating ball valve

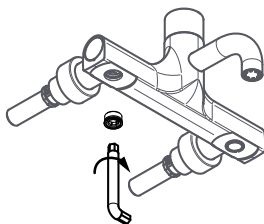

9 - Refit the hot inlet plug into the hot position and the cold into the cold position and refit the covers

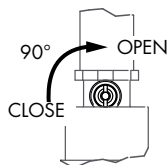

10 - Open the isolating ball valve, water may start to flow but will stop automatically

Temperature	Disinfection time
60°C	20 minutes
65°C	10 minutes
70°C	5 minutes

11 - Disinfection times based on water temperature

By carrying out the above procedure you are sterilizing the complete tap with hot water

When this Mixer is used in a DO8 Application the following Instructions apply:

Introduction

This Inta Thermostatic Mixer has been specifically designed and manufactured to meet the requirements of BS 7942: 2000 and NHS D08. The product has been independently tested and approved as a TYPE 3 valve under the TMV3 scheme.

Technical Specification

Outlet Temp Adjustment Range	30°C to 50°C
Temperature Stability	+ 2°C
Max. Hot Inlet Temp	85°C
Inlet Temperature Range	55°C to 65°C Hot Supply
0.5°C to 20°C	Cold Supply
Max. Working Pressure	10 bar Static
Min. Working Pressure	1.0 bar Dynamic
DO8 Working Pressure Ranges	1.0 to 5.0 bar High Pressure
Min. Temp Differential (Mix to Hot) for fail-safe	10°C
Max. Pressure inlet Differential	5:1

Application

This thermostatic mixer has been independently tested by WRc and certified as meeting the requirements of the NHS D08 specification under the TMV3 Scheme as being suitable for use on the following;

Code	Application	Range
HP-W	Basin	High Pressure

Installation

IMPORTANT – The following instructions must be read prior to the installation of any thermostatic mixing valve.

The installer should also be aware of his responsibility and duty of care to ensure that all aspects of the installation comply with all current regulations and legislations.

It has been brought to our attention that flushing water systems using certain chemicals may affect the workings of the valve, which may adversely affect its performance.

We recommend that following system flushing with chemicals, mixers are checked for correct operation.

1. It is essential that, before installing a thermostatic mixing valve, the supply conditions of the system to which the valve is intended to be fitted are checked to confirm compliance with the parameters as quoted within the Technical Specification above and conditions on which the approval is granted i.e. verify supply temperatures, supply pressures, risk assessments etc.

Installation

2. Consideration must be made for the possibility of multiple/ simultaneous demands being made on the supply system whilst the thermostatic mixing valve is in use, all practical pre-cautions must be made to ensure that the valve is not affected. Failure to make provision within the pipe sizing etc will affect the performance of the valve.
3. The supply system to which the Thermostatic Mixing Valve is to be installed into must be thoroughly flushed and cleaned to remove any debris (see page 13), which may be accumulated during the installation. Failure to remove any debris will affect the performance and the manufacturer's warranty on the product.
3. Independent filters/check valves and isolation valves must be fitted in conjunction with the valve. In areas that are subject to hard water, provision must be made to treat the supplies prior the supplies entering any product.
4. The maximum flow rate of the valve will only be achieved when the supply conditions are achieved as quoted, with a flow condition under 1 bar differential pressure.
5. This thermostatic mixer has been designed to be wall mounted. It is essential that access to the valve is not obstructed for future maintenance, that may be required to the valve or associated fittings.
6. The connection of the hot and cold supplies must be in accordance with the instructions shown above i.e. hot water connected to the left hand side of the valve when the nozzle is facing you.
7. In a situation where one or both of the water supplies are excessive, it is recommended to fit a Pressure Reducing Valve, WRAS approved product, to reduce the pressure(s) to within those stated in the Technical Specification previously stated or a suitable flow regulator.
8. We recommend that Y pattern strainers and full bore isolation valves are installed in conjunction with this product as close as practically possible to the location valve.
9. It is essential that this product should not be installed in situations where there is a possibility of the valve being deprived of water or where demands for water are greater than the actual stored supplies.
10. To ensure that the performance levels of this Thermostatic Mixing Valve are maintained (in the event of cold water failure) the temperature of the hot water supply at the point of entry to the valve must be a minimum of 10°C above the commissioned mixed water discharge temperature.
11. This Thermostatic Mixing Valve must not be subject to any extreme temperature variations either during the installation or under normal operating conditions.

Commissioning

IMPORTANT – The following instructions must be read and understood prior to the commissioning of a Thermostatic Mixer. If under any circumstances there are aspects to the installation/system which do not comply with the specification laid down, the valve **MUST NOT** be put into operation until the system/installation complies with our specification.

1. Ensure that the system is thoroughly cleaned and free from any debris prior to the commissioning of the valve. (See page 13)
2. The commissioning of the temperature must be carried out using a suitably calibrated thermometer – preferably a digital thermometer. (See page 10)
3. In the absence of other temperatures being specified we recommend that the outlet temperatures quoted in table 1 are used, extracted from the “National Health Service – Health Guidance Note – Safe Hot Water and Surface Temperatures”.

Table 1

Application	Recommended Set Hot Water Temperature
Wash Hand Basin	41°C

4. Each valve must be commissioned taking into consideration any fluctuations, which may occur within the system due to simultaneous demands. It is advisable that any outlets which are connected to the same supply as the mixing valve are opened during setting of the mixed water temperature. It is advisable to ensure that the water temperatures are established before any attempt to commission.
5. Once the supply temperatures are stable and the normal operating conditions are established, the valve can be commissioned. We suggest that the following sequence is followed when commissioning the valve:
 - 5.1 Wave your hand in front of the sensor to activate the tap, the mixed water temperature should be preset (see page 8).
 - 5.2 Measure and record the temperature of the hot and cold water supplies at the connections to the valve.
 - 5.3 Measure and record the temperature of the water discharging from the valve for the largest and smallest draw off point.
 - 5.4 Isolate the cold water supply to the valve and monitor the mixed water temperature.
 - 5.5 Measure and record the maximum mixed water temperature and the final temperature. The final temperature found during the test should not exceed the values quoted in table 2.
 - 5.6 Record all the equipment used during the commissioning.

Table 2

Application	Maximum Hot Water Temperature
Wash Hand Basin	43°C

Commissioning

6. Ensure that the application, to which the valve will be used, is appropriate for the approved designation.
7. The above information must be recorded and updated on every occasion when any work is carried out on the valve.

In Service Testing

To ensure that the Thermostatic Mixer maintains a high level of protection, we advise the following in service testing is followed (the same equipment used to commission the valve initially must be used in the following tasks).

1. After a period of between 6 and 8 weeks after commissioning carry out the following.
 - a) Record the temperature of the hot and cold water supplies.
 - b) Record the temperature of the mixed water at the largest draw off flow rate.
 - c) Record the temperature of the mixed water at the smallest draw off flow rate.
2. If the mixed water temperature has changed significantly from the previous test results (e.g. > 1 k), record the change and before re-setting the mixed water temperature check that:
 - a) All the strainers are clean
 - b) All the check valves are in good working order
 - c) The isolation valves are fully open.
3. If the mixed water temperature is acceptable, carry out the following:
 - a) Record the temperature of the hot and cold water supplies.
 - b) Record the temperature of the mixed water at the largest draw off flow rate.
 - c) Record the temperature of the mixed water at the smallest draw off flow rate.
 - d) Isolate the cold water supply to the mixing valve and monitor the mixed water temperature.
 - e) Record the maximum temperature achieved as a result and the final temperature (the final temperature should not exceed the values quoted in table 2)
 - f) Record the equipment used during these tests.
4. If during the test, paragraph 3, the mixed water temperature is greater than the values quoted in table 2 or the maximum temperature exceeds the corresponding values from previous test results by more than 2°C, the tap must be serviced.
5. After a period of between 12 and 15 weeks after commissioning, carry out the sequence of tests as described in 1, 2, 3 and 4 of this section.

In Service Testing

6. Dependant upon the results obtained from the first two series of tests; there are a number of possible outcomes.
 - a) If no significant change in the mixed water temperatures (e.g. $< 1^{\circ}\text{C}$) is recorded between commissioning and step 3e above or between commissioning and 5 of this section, the next in service testing should be carried out at a period of 24 to 28 weeks after initial commissioning.
 - b) If a small change (e.g. $1 - 2^{\circ}\text{C}$) in the mixed water temperature is recorded in only one of these periods, necessitating adjustment of the mixed water temperature, then the next in service test can be deferred to 24 to 28 weeks after commissioning.
 - c) If small change (e.g. $1 - 2^{\circ}\text{C}$) in the mixed water temperature is recorded in both of these periods, necessitating adjustment of the mixed water temperature, then the next in service test can be deferred to 18 to 21 weeks after commissioning.
 - d) If significant changes (e.g. $>2^{\circ}\text{C}$) in the mixed water temperature are recorded in both of these periods necessitating service work, then the next in service test should be carried out at 18 - 21 weeks after commissioning.
7. The general principle to be observed after the first two or three in service tests is that the intervals of future test should be set to those which previous tests have shown can be achieved with no more than a small change in mixed water temperature.
8. In all areas periodic maintenance of the valve and associated fittings i.e. strainers, check valves will ensure optimum performance levels are maintained.
9. On the inlet strainers on both the hot and cold water supply inlet can be removed for cleaning.
10. The built in check valves can be accessed in a similar way to the filters to ensure freedom and correct seating.

Please leave this Manual for the User

Guarantee

Intatec guarantees the product to be free from defects in materials and workmanship at the date of purchase. If the product is determined to be defective at the date of original purchase due to improper materials or workmanship and you inform us of this within the prescribed warranty period, (five years for showering products, one year for commercial products), of the date of purchase, Intatec will, without charge for labour or parts, repair or (at the discretion of Intatec) replace the product or its defective parts subject to the terms and limitations below. Intatec may replace defective products or parts with new or refurbished products or parts.

Guarantee services will be provided only if the original invoice or sales receipt (indicating the date of purchase and supplier's name) is presented with the defective product within the guarantee period.

The free of charge service may be refused if this information is not available. The guarantee will not apply if the product has not been installed correctly.

This guarantee does not cover (without limitation):

- Periodic maintenance or parts replacement due to wear and tear;
- Damage or defects caused by misuse in operation;
- Installation or use of the product inconsistent with good working practice;
- Failure to maintain the product in accordance with instructions;
- Repair or attempted repair by persons who are not qualified;
- Neglect

Consumers have legal (statutory) rights under applicable laws relating to the sale of consumer products. This guarantee does not affect statutory rights you may have or those rights that cannot be excluded or limited, nor rights against the person from whom you purchased the product. You may assert any rights you have at your sole discretion.

Notes:

Please leave this Manual for the User

To activate your product warranty please visit

www.intatec.co.uk

and click on Product Registration

Intatec Ltd

Airfield Industrial Estate
Hixon
Staffordshire
ST18 0PF

Tel: **01889 272 180**

Fax: **01889 272 181**

email: **sales@intatec.co.uk**

web: **www.intatec.co.uk**