

inta

Intamix

Thermostatic Mixing Valve

TMV2 & TMV3

Installation Guide

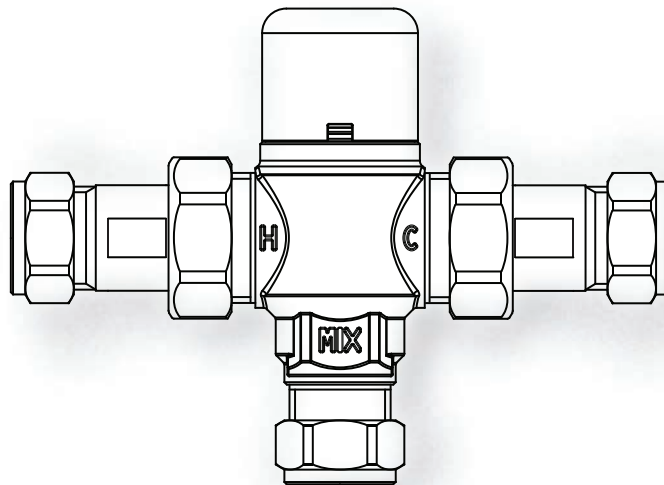

inta

Intatec Ltd
Airfield Industrial Estate
Hixon
Staffordshire
ST18 0PF

In this procedure document we have endeavoured to make the information as accurate as possible.
We cannot accept any responsibility should it be found that in any respect the information is inaccurate or incomplete or becomes so as a result of further developments or otherwise.

Tel: **01889 272 180**
Fax: **01889 272 181**
email: **sales@intatec.co.uk**
web: **www.intatec.co.uk**

Intamix TMV3 Thermostatic Mixing Valve

Introduction

The Intamix thermostatic mixing valves have been specifically designed and manufactured to meet the requirements of BS 7942:2011 and NHS D08. The valve has been independently tested and approved as a TYPE 3 valve under the TMV3 scheme.

Technical Specification / Conditions for use TMV3 Valves

Outlet Temperature Adjustment Range	30°C to 50°C
Temperature Stability	±2°C
Maximum Hot Inlet Temperature	85°C
DO8 Working Pressure Range	0.2 to 1.0 bar : Low Pressure - LP-SE 1.0 to 5.0 bar : High Pressure - HP-S
Min Temp Differential (Mix to Hot) for Fail-Safe	10°C
Max. Pressure Inlet Differential	5 : 1
Max. Flow Rate @ 1 bar Differential	Ø15mm 1500 l/hr (25 l/m) Ø22mm 1700 l/hr (28.3 l/m)

Operating Pressure Range	High Pressure	Low Pressure
Maximum Static Pressure	10 bar	10 bar
Flow Pressure, Hot and Cold	1 to 5 bar	0.2 to 1 bar
Hot Supply Temperature	55°C to 65°C	55°C to 65°C
Cold Supply Temperature	5°C to 20°C	5°C to 20°C

NOTE: Valves operating outside these conditions cannot be guaranteed by the Scheme to operate as Type 3 valves.

Approvals

TMV3 Scheme Approval Number: Details Available on Request

WRAS Scheme Approval Number: Details Available on Request

Fail Safe Function

The Intamix 15mm and 22mm valves are designed to stop the mixed water flow in the event of either the hot or cold water supply failing when installed in accordance with these instructions. To ensure thermal shut off the minimum temperature differential between the hot water inlet to the valve and the mixed water outlet **MUST be at least 10°C**.

Installation Guide TMV3

Dimensions

See Appendix A for dimensions with standard and MX union ends.

Flowrates

See Appendix B for pressure drops and flow chart.

Temperature Setting

Ensure that the valve is commissioned under normal system conditions. The valve **MUST** be commissioned to suit site conditions and the desired outlet temperature set by the installer;

- i. With normal supply conditions established and the hot and cold water supplies running, open the outlet fitting and leave running.
- ii. Remove the cap and release the locking nut from the temperature spindle.
- iii. Using an 8mm Allen key rotate the temperature adjustment spindle anticlockwise to increase the mixed water temperature or clockwise to reduce the mixed water temperature – at all times ensuring the probe of the thermostat is under the flowing water.
- iv. We recommend the use of a digital thermostat when setting the valve, once the desired outlet temperature is reached, re-fit the locking nut to the temperature spindle to prevent unauthorized adjustment of the valve and replace the cap on the valve body.

Application

The Intamix 15mm and 22mm thermostatic mixing valves have been independently tested by NSF and certified as meeting the requirements of the NHS D08 specification under the TMV3 Scheme as being suitable for use on the following designations;

Application	Range	Application	Range
Basin	High Pressure	Basin	Low Pressure - E
Bidet	High Pressure	Bidet	Low Pressure - E
Shower	High Pressure	Shower	Low Pressure - E
Bath (T44)*	High Pressure	* 22mm only	
Bath (T46)*	High Pressure		

Installation

IMPORTANT - The following instructions must be read prior to the installation of any Inta valve. The installer should also be aware of their responsibility and duty of care to ensure that all aspects of the installation comply with all current regulations and legislation.

Flushing through water systems using certain chemicals may wholly or partially remove the lubricant from the internal workings of the valve, which may adversely affect its performance. We recommend that following a flushing of the system with chemicals, valves are checked for correct operation.

- 1 It is essential that before installing Inta 15mm and 22mm valves ensure that the supply conditions of the system to which the valves are intended to be fitted are checked to confirm compliance with the parameters as quoted within the Technical Specification and conditions on which the approval is granted i.e. verify supply temperatures, supply pressures, risk assessment.

Installation

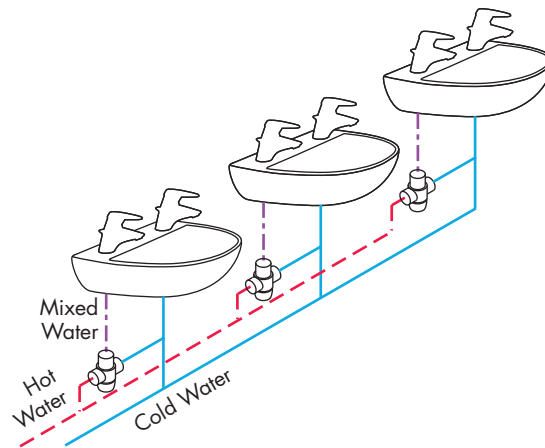

- 2 Consideration must be made for the possibility of multiple / simultaneous demands being made on the supply system whilst the Inta 15mm and 22mm valves are in use, all practical precautions must be made to ensure that the valves are not affected. Failure to make provision within the pipe sizing etc. will affect the performance of the valves.
- 3 The supply system to which the Inta valves are to be installed into must be thoroughly flushed and cleaned to remove any debris, which may have accumulated during the installation. Failure to remove any debris will affect the performance and the manufacturer's warranty of the product. Independent filters / check valves and isolation valves must be fitted in conjunction with the valves, as close as practically possible to the water supply inlets of the Inta thermostatic valve. In areas that are subject to aggressive water, provision must be made to treat the water supply prior to the supply entering any product.
- 4 The maximum flow rate of the valve will only be achieved when the supply conditions are achieved as quoted within the Technical Specification, with a flow condition under 1 bar differential pressure.
- 5 The Inta 15mm and 22mm valves have been designed to ensure that the valves can be installed in any position whether vertical or horizontal, they can be surface mounted or within a supply duct. It is essential that the access to the valve is not obstructed for any future maintenance that may be required to the valve or associated fittings.
- 6 We recommend that the Inta fail-safe thermostatic mixing valves be installed as close as practically possible to the outlet, which it is serving. In this situation attention must be paid to the maximum distance of pipe work from the mixed water outlet of the valve to any terminal fitting. NHS Estate's current guidelines recommend a maximum distance of 2m from the outlet of the mixing valve to the terminal fitting, which the mixing valve is to serve.
- 7 The hot and cold water supplies must be connected to the valve strictly in accordance with the indications on the body of the valve i.e. hot water supply to the hot port of the valve.
- 8 In a situation where one or both of the water supplies are excessive, it is possible to fit a pressure reducing valve to reduce the pressure(s) to within the limits as quoted previously.
- 9 Any thermostatic mixing valve must be fitted with a back flow prevention device, such as check valves to prevent the cross contamination of supplies. The Inta valves are complete with integral insert check valves and strainers. However if required, additional WRAS approved backflow prevention devices should be positioned as close as practically possible to the water supply inlets of the Inta thermostatic mixing valve.
- 10 Y Pattern strainers and full-bore isolation valves must be installed in conjunction with the Inta fail-safe thermostatic mixing valves as close as is practically possible to the location of the valve.

Installation Guide TMV3

Installation

- 11 It is essential that the Inta fail-safe thermostatic mixing valves should not be installed in situations where there is a possibility of the valve being deprived of water or where demands for water are greater than the actual stored supplies.
- 12 To ensure that the performance levels of the Inta thermostatic mixing valves are maintained (in the event of cold water failure), the temperature of the hot water supply at the point of entry to the valves must be a minimum of 10°C above the commissioned mixed water discharge temperature.
- 13 The Inta fail-safe thermostatic mixing valves must not be subject to any extreme temperature variations either during the installation or under normal operating conditions.

Commissioning

IMPORTANT - The following instructions must be read and understood prior to the commissioning the 15 mm and 22mm Inta fail-safe thermostatic mixing valves. If under any circumstances there are aspects to the installation / system which do not comply with the specification laid down, the valve **MUST NOT** be put into operation until the system / installation complies with our specification. However if all these conditions are met, proceed to set the temperature as follows;

- 1 Ensure that the system is thoroughly cleaned and free from any debris prior to the commissioning of the Inta fail-safe thermostatic mixing valve.
- 2 Commissioning the temperatures must be carried out using a suitably calibrated thermometer - preferably a digital thermometer.
- 3 In the absence of other temperatures being specified, we recommend the outlet temperatures quoted in Table 1 are used.

Table 1

Application	Recommended Set Mixed Water Temp.
Wash Hand Basin	41°C
Shower	41°C
Bidet	38°C
Bath Fill	44°C

- Note 1:** For washbasins, washing under running water is assumed.
- Note 2:** Bath fill temperatures of more than 44°C should only be available when the bather is always under the supervision of a competent person (e.g. nurse or care assistant)
- Note 3:** The Inta thermostatic mixing valve is capable of satisfying the entire above multiple designations and should be re-set on-site according to its specific designation.

- 4 Each valve must be commissioned taking into consideration any fluctuations, which may occur within the system due to simultaneous demands. It is advisable that any outlets which are connected to the same supply as the mixing valve are opened during the setting of the mixed water temperature. During commissioning it is advisable to ensure that the water temperatures are established before any attempt to commission.

Installation Guide TMV3

Commissioning

- 5 Once the supply temperatures are stable and the normal operating conditions are established, the valve can be commissioned. The temperature setting can be adjusted by removing the head from the valve body and adjusting the temperature adjustment spindle. We suggest that the following sequence is followed when commissioning the valve:
 - 5.1 Set the mixed water temperature to the required temperature.
 - 5.2 Measure and record the temperature of the hot and cold water supplies at the connection to the valve.
 - 5.3 Measure and record the temperature of the water discharging from the valve from the largest and smallest draw off point.
 - 5.4 Isolate the cold water supply to the valve and monitor the mixed water temperature.
 - 5.5 Measure and record the maximum mixed water temperature and the final temperature. The final temperature found during the test should not exceed the values quoted in Table 2.
 - 5.6 Record all the equipment used during the commissioning.

Table 2

Application	Maximum Set Mixed Water Temp.
Wash Hand Basin	43°C
Shower	43°C
Bidet	40°C
Bath Fill	46°C

Note: Bath fill temperatures of more than 44°C should only be available when the bather is always under the supervision of a competent person (e.g. nurse or care assistant)

- 6 Once the desired temperature is established remove the cap and secure the temperature spindle with the locking ring and replace the cap into its original position to prevent tampering by unauthorized persons.
- 7 Ensure that the application, in which the valve will be used, is appropriate for the approved designation. The above information must be recorded and updated on every occasion when any work is carried out on the valve.

Maintenance

To ensure that the 15mm and 22mm Inta valves maintains a high level of protection, we advise the following in service testing is conducted (the same equipment used to commission the valve initially must be used in the following tasks).

- 1 After a period of between 6 and 8 weeks from commissioning carry out the following;
 - 1.1 Record the temperature of the hot and cold water supplies.
 - 1.2 Record the temperature of the mixed water at the largest draw off flow rate.
 - 1.3 Record the temperature of the mixed water at the smallest draw off flow rate.
- 2 If the mixed water temperature has changed significantly from the previous test results (e.g. >1°K), record the change and before resetting the mixed water temperature check that:
 - 2.1 All the strainers are clean.
 - 2.2 All the check valves are in good working order.
 - 2.3 The isolation valves are fully open

Maintenance

- 3 If the mixed water temperatures are acceptable, carry out the following:
 - 3.1 Record the temperature of the hot and cold water supplies
 - 3.2 Record the temperature of the mixed water at the largest draw off flow rate
 - 3.3 Record the temperature of the mixed water at the smallest draw off flow rate
 - 3.4 Isolate the cold water supply to the mixing valve and monitor the mixed water temperature
 - 3.5 Record the maximum temperature achieved as a result of (3.4) and the final temperature (the final temperature should not exceed the values quoted in table 2)
 - 3.6 Record the equipment used during these tests.
- 4 If the mixed water temperature is greater than the values quoted in table 2 or the maximum temperature exceeds the corresponding values from previous test results by more than 2°K, the valve must be serviced.
- 5 After a period of between 12 to 15 weeks from commissioning, carry out the sequence of tests as described in Maintenance sections 1, 2, 3 and 4.
- 6 Dependant upon the results obtained from the first two series of tests; there are a number of possible outcomes:
 - 6.1 If no significant change in the mixed water temperatures (e.g. $\leq 1^{\circ}\text{K}$) is recorded between commissioning and Maintenance sections 1 or between commissioning and Maintenance sections 5, the next in service testing should be carried out at a period of 24 to 28 weeks after initial commissioning.
 - 6.2 If a small change (e.g. 1 to 2°K) in the mixed water temperature is recorded in only one of these periods, necessitating adjustment of the mixed water temperature, then the next in service can be deferred to 24 to 28 weeks after commissioning.
 - 6.3 If small changes (e.g. 1 to 2°K) in the mixed water temperature are recorded in both of these periods, necessitating adjustment of the mixed water temperature, then the next in service test can be deferred to 18 to 21 weeks after commissioning.
 - 6.4 If significant changes (e.g. $> 2^{\circ}\text{K}$) in the mixed water temperature are recorded in both of these periods necessitating service work, then the next in service test should be carried out at 18 to 21 weeks after commissioning.
- 7 The general principle to be observed after the first 2 or 3 in-service tests is that the intervals for future tests should be set to those which previous tests have shown can be achieved with no more than a small change in mixed water temperature.
- 8 In all areas periodic maintenance of the valve and associated fittings i.e. strainers, check valves will ensure optimum performance levels are maintained.
- 9 The inlet strainers on both the hot and cold water supplies can be removed for cleaning by unscrewing the inlet union nuts and carefully pulling apart the connecting pipework.
- 10 The built in check valves can be accessed to ensure freedom and correct seating.

NOTE: If the mixing valve has not been used for an extended period of time, it is recommended that the system is flushed before servicing and recommissioning the valve to ensure correct operation.

Installation Guide TMV3

Spares

A full range of spares are available for this product from Inta.

PLEASE NOTE: Only genuine spares should be used.

Problem Solving

The following details are supplied for on site queries, should you require any further assistance our Technical Department can be contacted directly on 01889 272199

1 Hot water at the cold tap

- i. Operation of the insert check valves is hindered, check the valve is seated correctly.
- ii. Check Valves not fitted.
- iii. Unbalanced hot/cold supply pressure.

2 Fluctuating mixed water temperature

- i. Erratic supply temperatures at the inlets of the valve.
- ii. Starvation of the water supplied at the inlets of the valve.
- iii. Incorrect commissioning of the valve.

3 Erratic flow

- i. Insufficient water supplies.
- ii. Fluctuations in the supply pressures/temperatures.
- iii. Adverse effect created by other draw off points on the system.

4 No flow/reduced flow from valve

- i. In line filters are blocked.
- ii. Insufficient supply pressure.
- iii. Debris obstructing valve operation.
- iv. Valve requires servicing (Servicing kits available from your local stockist).

5 Valve does not fail safe when tested

- i. Installation not in accordance with our recommendations.
- ii. The minimum temperature differential not achieved.
- iii. Internal mechanism hindered by debris.

Full and detailed instructions are supplied with service kits and are available on request.

Please leave this Manual for the User

Intamix TMV2 Thermostatic Mixing Valve

The following information is required for use when the Intamix range of thermostatic mixing valves is used in TMV2 Applications under the requirements of BS EN 1111: 2017 "Sanitary tapware. Thermostatic Mixing Valve (PN 10). General Technical Specification" and BS EN 1287: 2017 "Sanitary tapware. Low pressure thermostatic mixing valves. General technical specifications".

Introduction

The Inta range of thermostatic mixing valves have been specifically designed and manufactured to meet the requirements of BS EN 1111:2017 and BS EN 1287:2017* TMV2 Type Scheme. The valve has been independently tested and approved as a TYPE 2 valve under the NSF TMV2 scheme by the NSF Testing & Evaluation Center.

* Note: Applies to 22mm valve only.

Technical Specification / Conditions for use TMV2 Valves

	High Pressure BS EN 1111	Low Pressure BS EN 1287
Max. Static Pressure	10 bar	10 bar
Flow Pressure, Hot & Cold	0.5 - 5 bar	0.1 - 1 bar
Hot Supply Temperature	55°C - 65°C	55°C - 65°C
Cold Supply Temperature	≤25°C	≤25°C
Temperature Stability	±2°C	±2°C
Min. Temp Differential (Mix to Hot) for fail-safe	10°C	10°C
Max. Pressure Inlet Differential	5:1	5:1

NOTE: Valves operating outside these conditions cannot be guaranteed by the Scheme to operate as Type 2 valves.

Approvals

NSF Scheme Approval Number:

Details Available on Request

WRAS Scheme Approval Number:

Details Available on Request

Dimensions

See Appendix A for dimensions with standard and MX union ends.

Flowrates

See Appendix B for Kv values and flow charts.

Installation Guide TMV2

Application

The Intamix thermostatic mixing valves have been independently tested by NSF and certified as meeting the requirements of BS EN 1111:2017 and BS EN 1287:2017* under the TMV2 scheme as being suitable for use on the following designations.

*Note: applies to 22mm valve only.

This product is designed and certified for the following designations

Application	Range	Application	Range
Basin	High Pressure	Basin	Low Pressure
Bidet	High Pressure	Bidet	Low Pressure
Shower	High Pressure	Shower	Low Pressure
Bath Fill*	High Pressure	* 22mm only	

NOTE: Applies to HP installations only. If a water supply is fed by gravity then the supply pressure should be verified to ensure the conditions of use are appropriate for the valve. The installation of thermostatic mixing valves must comply with the requirements of the Water Supply (Water Fittings) Regulations 1999.

Recommended Outlet Temperatures

The NSF TMV scheme recommends the following set maximum mixed water outlet temperatures for use in all premises:

Application	Recommended Set Mixed Water Temp.
Wash Hand Basin	41°C
Shower	41°C
Bidet	38°C
Bath Fill	44°C

The mixed water temperatures must never exceed 46°C. The maximum mixed water temperature can be 2°C above the recommended maximum set outlet temperatures.

NOTE: 46°C is the maximum mixed water temperature from the bath tap. The maximum temperature takes account of the allowable temperature tolerances inherent in the thermostatic mixing valves and temperature losses in metal baths. It is not a safe bathing temperature for adults or children.

The British Burns Association recommends 37°C to 37.5°C as a comfortable bathing temperature for children. In premises covered by Care Standards Act 2000, the maximum mixed water outlet temperature is 43°C

Installation Guide TMV2

Installation

IMPORTANT - The following instructions must be read prior to the installation of the Intamix thermostatic mixing valves, the installer should also be aware of their responsibility and duty of care to ensure that all aspects of the installation comply with all current regulations and legislation. It has been brought to our attention that flushing through water systems using certain chemicals may wholly or partially remove the lubricant from the internal workings of the valve, which may adversely affect its performance. We recommend that following flushing of the system with chemicals; valves are checked for correct operations.

The installation of thermostatic mixing valves must comply with the requirements of the Water Supply (Water Fittings) Regulations 1999.

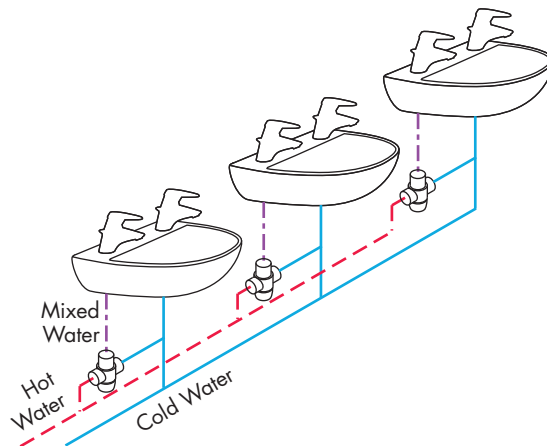

The Inta range of thermostatic mixing valves **MUST** be installed in an accessible position to ensure that maintenance, commissioning and testing of the **Inta Thermostatic Mixing Valves** can be undertaken easily.

- 1 It is essential that before installing any of the Intamix thermostatic mixing valves to ensure that the supply conditions of the system to which the valve is intended to be fitted are checked to confirm compliance with the parameters as quoted within the Technical Specification and conditions on which the approval is granted i.e. verify supply temperatures, supply pressures, risk assessment.
- 2 Consideration must be made for the possibility of multiple / simultaneous demands being made on the supply system whilst the Inta thermostatic mixing valves is in use, all practical precautions must be made to ensure that the valve is not affected. Failure to make provision within the pipe sizing etc. will affect the performance of the valve.
- 3 The supply system to which the Inta thermostatic mixing valve is to be installed into must be thoroughly flushed and cleaned to remove any debris, which may have accumulated during the installation. Failure to remove any debris will affect the performance and the manufacturer's warranty of the product. Independent filters / check valves and isolation valves must be fitted in conjunction with the valve. In areas that are subject to aggressive water, provision must be made to treat the water supply prior to the supply entering any Inta product.
- 4 The maximum flow rate of the valve will only be achieved when the supply conditions are achieved as quoted within the Technical Specification, with a flow condition under 1 bar differential pressure.
- 5 The Inta range of thermostatic mixing valves have been designed to ensure that the valve can be installed in any position whether vertical or horizontal, it can be surface mounted or within a supply duct. It is essential that access to the valve is not obstructed for any future maintenance that may be required to the valve or associated fittings.
- 6 We recommend that the Inta failsafe thermostatic mixing valve be installed as close as practically possible to the outlet, which it is serving. In this situation attention must be paid to the maximum distance of pipe work from the mixed water outlet of the valve to any terminal fitting.
- 7 Current guidelines recommended a maximum distance of 2m from the outlet of any mixing valve to the furthest terminal fitting / outlet to which the mixing valve is to serve.
- 8 The hot and cold water supplies must be connected to the valve strictly in accordance with the indications on the body of the valve i.e. hot water supply to the hot port of the valve.

Installation Guide TMV2

Installation

- 9 In a situation where one or both of the water supplies are excessive, it is possible to fit a pressure reducing valve to reduce the pressure(s) to within the limits as quoted previously.
- 10 Any thermostatic mixing valve must be fitted with a back flow prevention device, such as check valves to prevent the cross contamination of supplies. The Inta range of thermostatic mixing valves is complete with integral insert check valves and strainers.
- 11 Y Pattern strainers and full-bore isolation valves must be installed in conjunction with the Inta range of fail-safe thermostatic mixing valves – the Y Pattern Strainers and isolation ball valves must be fitted as close as practically possible to the valve. Alternatively the use of the MX optional tail pieces removes the need for additional filters and isolation valves.
- 12 It is essential that the Inta range of fail-safe thermostatic mixing valves should not be installed in situations where there is a possibility of the valve being deprived of water or where demands for water are greater than the actual stored supplies.
- 13 To ensure that the performance levels of the Inta range of thermostatic mixing valves are maintained (in the event of cold water failure), the temperature of the hot water supply at the point of entry to the valves must be a minimum of 10°C above the commissioned mixed water discharge temperature.
- 14 The Inta range of fail-safe thermostatic mixing valves must not be subject to any extreme temperature variations either during the installation or under normal operating conditions.

Method of Adjusting the Mixed Water Outlet Temperature

IMPORTANT - The following instructions must be read and understood prior to the adjustment of the mixed water outlet temperature and this action **MUST** only be carried out by a suitably qualified person.

- 1 Remove the cap from the valve
- 2 Remove the temperature locking ring from the spindle using a suitably sized spanner
- 3 Open the outlet to which the mixing valve is supplying and establish as stable flow and temperature
4. Using a calibrated thermometer place the sensing part of the thermometer probe under the flowing water
- 5 Using an 8mm Allen key rotate the temperature adjustment spindle anticlockwise to increase the mixed water temperature or clockwise to reduce the mixed water temperature – at all times ensuring the probe of the thermostat is under the flowing water.
- 6 Once the desired temperature is reached – replace the temperature locking ring on the spindle and re fit the cap of the valve.
- 7 **The temperature at the terminal fitting must never exceed 46°C.**

Commissioning

IMPORTANT - The following instructions must be read and understood prior to the commissioning the Inta range of thermostatic mixing valves. When measuring any mixed water outlet temperature reading, the sensing part of the thermometer probe must be fully submerged in the water. If under any circumstances there are aspects to the installation / system which do not comply with the specification laid down, the valve **MUST NOT** be put into operation until the system / installation complies with our specification. However if all these conditions are met, proceed to set the temperature as follows;

- 1 Ensure the designation of thermostatic mixing valves matches the application and that the system is thoroughly cleaned and free from any debris prior to the commissioning of the Inta range of thermostatic mixing valves. The supply temperatures and pressures are within the valves operating range specified. Providing that all of these conditions are met, please follow the following steps to commission this product

Commissioning

- 2 The commissioning of the temperatures must be carried out using a suitably calibrated thermometer – preferably a digital thermometer the sensing part of the thermometer probe must be fully submerged in the water when testing.
- 3 Each Valve must be commissioned taking into consideration any fluctuations, which may occur within the system due to simultaneous demands. It is advisable that any outlets which are connected to the same supply as the mixing valve is connected to are open during the setting of the mixed water temperature. During commissioning it is advisable to ensure that the water temperatures are established before any attempt to commission.
- 4 Once the supply temperatures are stable and the normal operating conditions are established, the valve can be commissioned, – the temperature setting can be adjusted by removing the cap and temperature locking ring from the valve body (see section method of adjusting mixed water temperature). We suggest that the following sequence is followed when commissioning the valve;
 - 4.1 Set the mixed water temperature to the required temperature, the temperature at the terminal fitting must never exceed 46°C.
 - 4.2 Measure and record the temperature of the hot and cold water supplies at the connection to the valve.
 - 4.3 Measure and record the temperature of the water discharging from the valve.
 - 4.4 Isolate the cold water supply to the valve and monitor the mixed water temperature.
 - 4.5 Measure and record the maximum mixed water temperature and the final temperature. The final temperature found during the test should not exceed the values quoted
 - 4.6 Record all the equipment used during the commissioning.
 - 4.7 The mixed water temperature at the terminal fitting must never exceed 2°C above set temperature.
 - 4.8 The maximum mixed water supply temperature at the terminal fitting should not exceed 46°C.
- 5 Once the desired temperature is established secure the temperature spindle with the locking ring and replace the cap into its original position to prevent tampering by unauthorized persons. Ensure that the application, in which the valve will be used in, is appropriate for the approved designation.
- 6 The above information must be recorded and updated on every occasion when any work is carried out on the valve.

In Service Testing

The Inta range of thermostatic mixing valves should be tested against the original set temperature results once a year. It is a requirement that all TMV2 approved valves shall be verified against the original set temperature results once a year. When commissioning/testing is due the following performance checks shall be carried out. When measuring any mixed water outlet temperature reading the sensing part of the thermometer probe must be fully submerged in the water.

When testing is due the following performance checks shall be carried out;

- 1 Measure the mixed water temperature at the outlet.
- 2 Carry out the cold water supply isolation test by isolating the cold water supply to the TMV, wait for five seconds if water is still flowing check that the temperature is below 46°C for bath fill and 43°C for wash basin and showers.
- 3 If there is no significant change to the set outlet temperature ($\pm 2^\circ\text{C}$ or less change from the original settings) and the fail-safe shut off is functioning, then the valve is working correctly and no further service work is required.
- 4 If there is a residual flow during the commissioning or the annual verification (cold water supply isolation test), then this is acceptable providing the temperature of the water seeping from the valve is no more than 2°C above the designated maximum mixed water outlet temperature setting of the valve. Temperature readings should be taken at the normal flow rate after allowing for the system to stabilise

Installation Guide TMV2

In Service Testing

- 5 If the Inta range of thermostatic mixing valves has been adjusted or serviced it must be re-commissioned and re-tested in accordance with these instructions.

Problem Solving

The following details are supplied for on site queries, should you require any further assistance our Technical Department can be contacted directly on 01889 272199

1 Hot water at the cold tap

- i. Operation of the insert check valves is hindered, check the valve is seated correctly.
- ii. Check Valves not fitted.
- iii. Unbalanced hot/cold supply pressure.

2 Fluctuating mixed water temperature

- i. Erratic supply temperatures at the inlets of the valve.
- ii. Starvation of the water supplied at the inlets of the valve.
- iii. Incorrect commissioning of the valve.

3 Erratic flow

- i. Insufficient water supplies.
- ii. Fluctuations in the supply pressures/temperatures.
- iii. Adverse effect created by other draw off points on the system.

4 No flow/reduced flow from valve

- i. In line filters are blocked.
- ii. Insufficient supply pressure.
- iii. Debris obstructing valve operation.
- iv. Valve requires servicing (Servicing kits available on request).

5 Valve does not fail safe when tested

- i. Installation not in accordance with our recommendations.
- ii. The minimum temperature differential not achieved.
- iii. Internal mechanism hindered by debris.

Please leave this Manual for the User

Intamix TMV - Appendix A

Dimensions

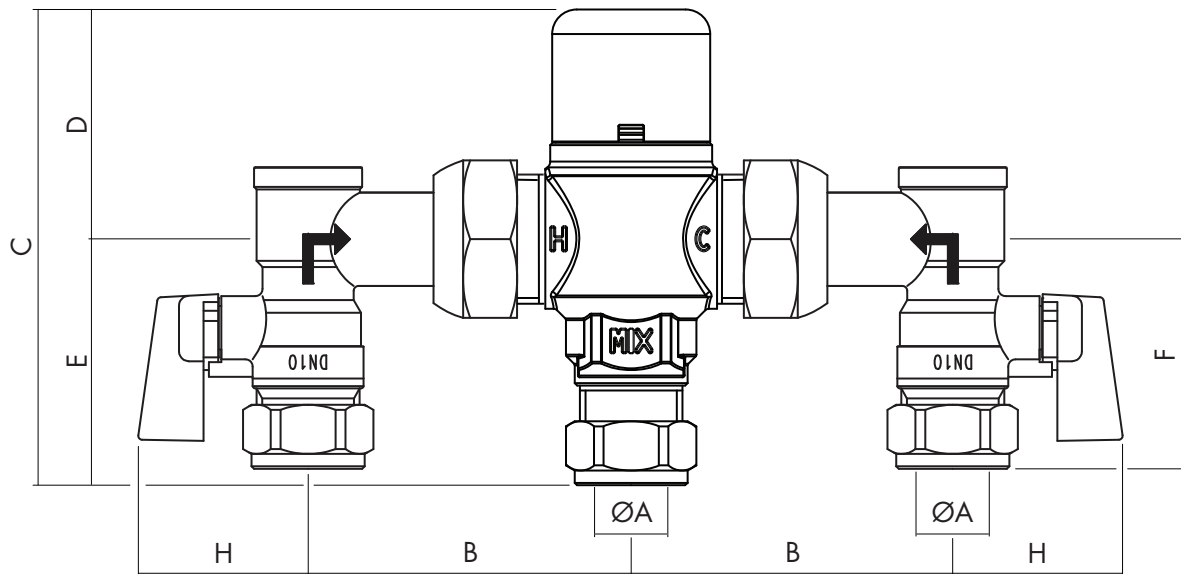
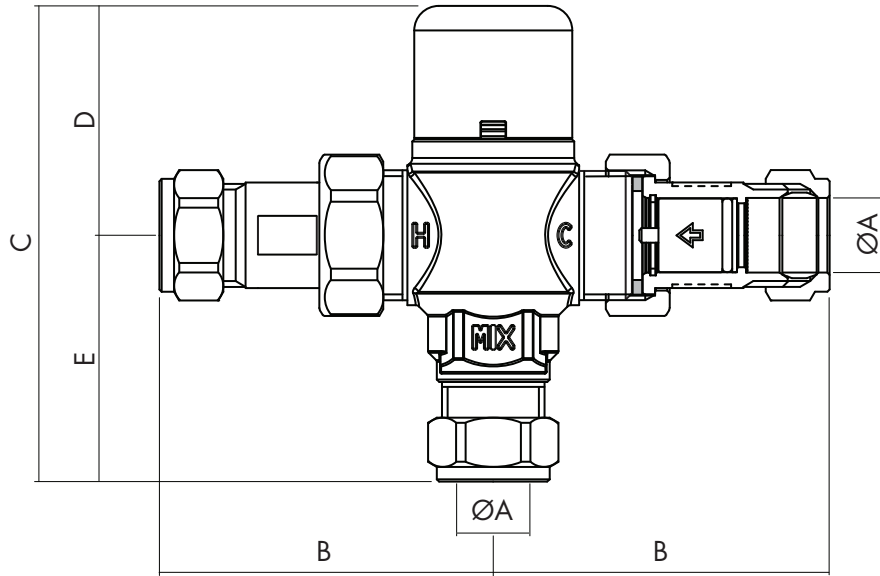

Code	A mm	B mm	C mm	D mm	E mm	F mm	H mm	Weight kg
40015CP	15	70.5	98	47	51	N/A	N/A	0.5
40022CP	22	71	98	47	51	N/A	N/A	0.6
400MX15CP	15	63	98	47	51	47	33	0.65
400MX22CP	22	64	98	47	51	54	33	0.75

Intamix TMV - Appendix B

Flowrates

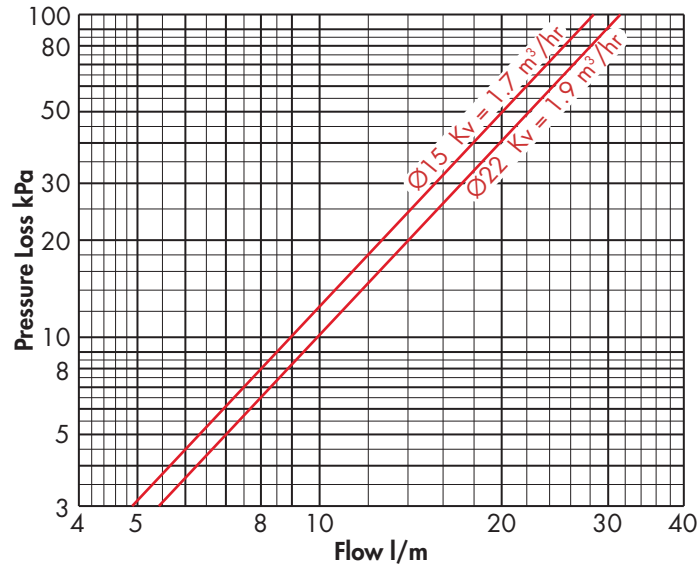

To activate your product warranty please visit
www.intatec.co.uk
and click on Product Registration