

inta

Intatherm Safe Touch Mixer IT1005RS and IT1006RS Installation and Maintenance Instructions

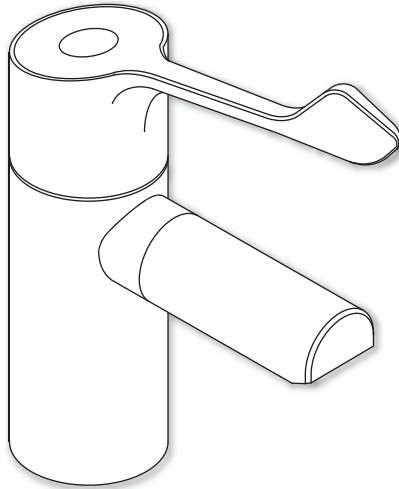

inta

Intatec Ltd

Airfield Industrial Estate
Hixon
Staffordshire
ST18 0PF

In this procedure document we have endeavoured to make the information as accurate as possible.

We cannot accept any responsibility should it be found that in any respect the information is inaccurate or incomplete or becomes so as a result of further developments or otherwise.

Tel: **01889 272 180**

Fax: **01889 272 181**

email: **sales@intatec.co.uk**

web: **www.intatec.co.uk**

Introduction

This installation guide has been produced for the Intatherm safe touch thermostatic basin mixer taps with detachable spout. These instructions cover the installation, operation and maintenance. Please read the enclosed instructions before commencing the installation of this product, please note;

We recommend that the installation of any Inta product is carried out by an approved installer.

The installation must be carried out strictly in accordance with the Water Supply (Water Fitting) Regulations 1999 and any local authority regulations.

If in doubt we recommend that you contact WRAS - Water Regulations Advisory Scheme on Tel: 0333 207 903, your local water authority - details available on the WRAS website or the Chartered Institute of Plumbing and Heating Engineers on Tel: 01708 472 791.

All products **MUST** be re-commissioned to suit site conditions to ensure optimum performance levels of the product are obtained.

Safety

The Intatherm safe touch basin mixer tap contains an integral thermostatic cartridge to prevent scalding.

This thermostatic mixer tap must be installed and commissioned correctly to ensure that water is supplied at a safe temperature to suit the users.

43°C is the maximum mixed water temperature from a mixer tap. The maximum temperature takes account of the allowable tolerances inherent in thermostatic mixer taps and temperature losses.

It is not a safe washing temperature for adults or children.

The British Burns Association recommends 37 to 37.5°C as a comfortable washing temperature for children. In premises covered by the Care Standard Act 2000, the maximum mixed water outlet temperature is 43°C.

Products

Intatherm safe touch basin mixer tap with detachable spout and copper tails IT1005RS

Intatherm safe touch basin mixer tap with detachable spout and extended lever and copper tails IT1006RS

Check Content

Before commencing remove all components from packaging and check each component with the contents list.

Ensure all parts are present, before discarding any packaging. If any parts are missing, do not attempt to install your Inta tap until the missing parts have been obtained.

Components

Item	Qty	Component
1	1	Body
2	1	Detachable spout
3	1	Nozzle-
4	1	Grub screw
5	1	Indice
6	1	Retaining screw
7	1	Handle
8	1	Temperature stop ring
9	1	Thermostatic cartridge
10	1	Seat
11	1	Sealing ring
12	1	Horse shoe plate
13	1	Threaded rod
14	1	Retaining nut
15	2	350mm copper tail integral with body
16	2	Connector with check valve and filter

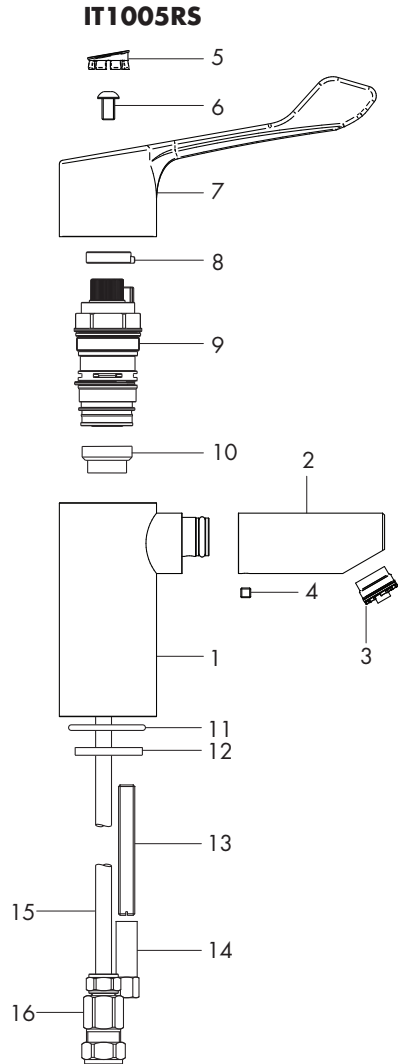

Technical Data

This Intatherm thermostatic mixer tap is suitable for installations on all types of plumbing system, including gravity supplies, fully pumped, modulating combination boiler, unvented water heater and unbalanced supplies i.e. Cold Mains & Tank Fed Hot. They are not suitable for non-modulating combination boilers.

Max Inlet Pressure (Static)	10 bar	Max Unbalanced Pressure Ratio	15:1
Max Inlet Pressure (Dynamic)	5 bar	with flow regulator	
Min Operating Pressure (Dynamic)	0.2 bar	Max Unbalanced Pressure Ratio	5:1
Max Inlet Temperature	85°C	without flow regulator	
Min Inlet Temperature	10°C	Min Temp Differential to	
Pre Set Factory Temp Setting	38°C	ensure fail-safe between hot	
Temperature Stability	±2°C	and cold supplies	10°C

Dimensions

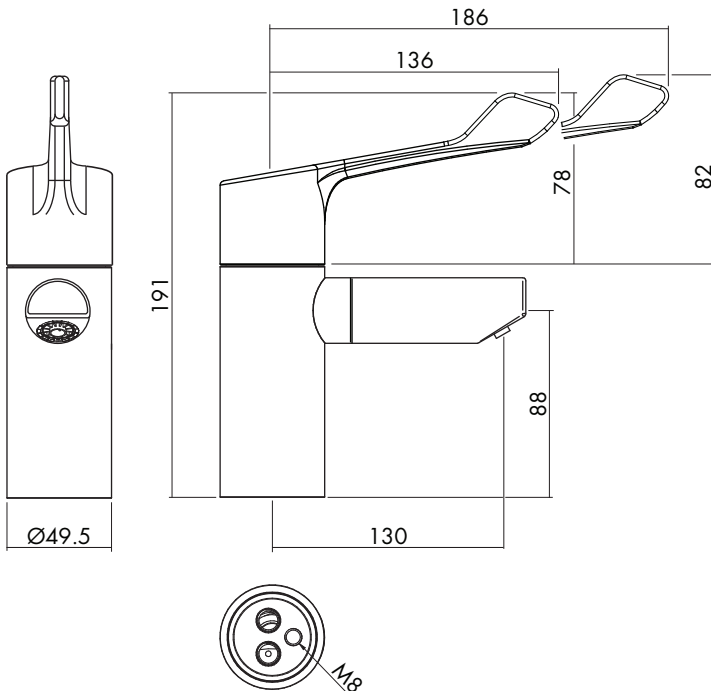

Installation

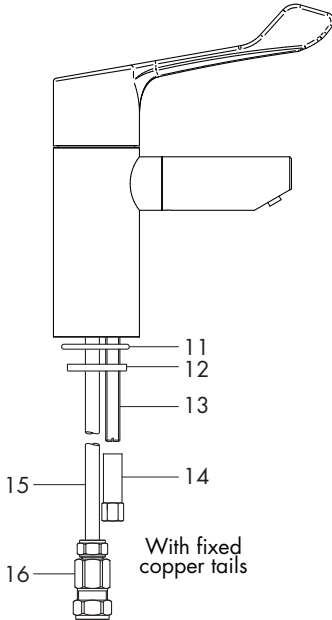

Installation

The Intatherm thermostatic basin tap is designed for installing on one hole basins.

The IT1005RS and IT1006RS taps are supplied with two 350mm long copper tails already fitted to the tap. Each tail is supplied ready to connect to the compression connector with integral check valve and filter (17).

The IT1005RS and IT1006RS taps are supplied ready to connect to the connector with integral check valve and filter (16).

Screw the threaded rod (13) into the threaded hole in the base of the body taking care not to over tighten.

The cold supply must be connected to the right hand side and the hot to the left hand side of the mixer when viewed from the front.

Ensure that the 'O' ring seal (11) is located in the base of the tap prior to fitting the mixer to the basin.

Once in place using the horse shoe retaining plate (12) secure in position, taking care not to over tighten the retaining nut (14).

Connect the connectors (16) to the tails and to the hot and cold supplies remembering which was connected to the hot inlet and ensure all joints are water tight.

For optimum mixing performance where the hot and cold pressures are not equal, regulating valves should be installed directly upstream of the tap so that the water supply pressures can be regulated and equalised.

Calibration

The Intatherm safe touch mixer tap has a factory set outlet temperature of 38°C via the security setting. This is based on a balanced supply pressure and a stable hot water inlet temperature of 65°C.

However, the calibration point **MUST** be checked and re-set as necessary to suit site conditions.

Care must be taken when re-calibrating the tap as **INCORRECT CALIBRATION CAN CAUSE INJURY**.

- Remove the indice (5), retaining screw (6), handle (7) and the temperature stop ring (8).
- Temporarily refit the handle (7) and move to the position for the hottest water and allow the outlet temperature to stabilise.
- Using a digital thermometer it is possible to increase or reduce the mixed water outlet temperature until 38°C is re-established, by slowly rotating the handle.
- Remove the handle (7) and refit the temperature stop ring (8) onto the splined section of the cartridge at the maximum temperature position.
- Refit the handle in the reverse order.

PLEASE NOTE THAT ONCE CALIBRATED, THE SECURITY SETTING WILL ONLY BE 38 °C UNDER THE SUPPLY CONDITIONS USED FOR CALIBRATION.

Cartridge Replacement

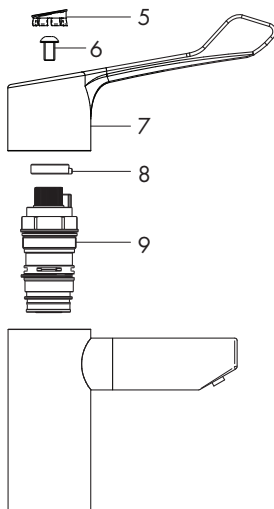

Isolate both the hot and cold water supplies

Remove the indice (5), and unscrew retaining screw (6).

Remove the handle (7) and the temperature stop ring (8).

Using a suitable spanner unscrew the cartridge (9).

Replace with a new cartridge and assemble in the reverse order.

Aftercare and Spout Removal

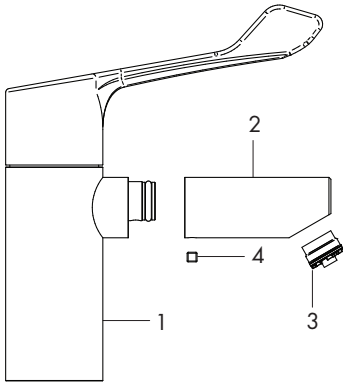

Periodically the spout and nozzle should be removed, cleaned and disinfected to remove any build up of debris, deposits or bio film which may affect the performance of the tap.

Ensure the tap is turned off before commencing.

Using a suitably sized spanner remove the nozzle (3) from the spout.

Unscrew the grub screw (4) and pull the spout (2) from the tap body (1).

Thoroughly clean and disinfect the nozzle and spout.

Check the condition of the 'O' ring on the tap body if damage replace with a new one.

To ease assembly lubricate the 'O' ring with washing up liquid.

Re-assemble in the reverse order.

Inta taps have a high quality finish and should be treated with care.

An occasional wipe with a mild washing-up liquid on a soft damp cloth followed by a thorough rinsing is all that is required.

Do not use an abrasive or chemical household cleaner as this may cause damage.

Intatherm TMV3 Thermostatic Basin Tap

Introduction

The Intatherm safe touch thermostatic basin tap has been specifically designed and manufactured to meet the requirements of BS 7942: 2011 and NHS D08. The valve has been independently tested and approved as a TYPE 3 valve under the TMV3 scheme.

Technical Specification / Conditions for use TMV3 Valves

Outlet Temperature Adjustment Range	30°C to 50°C
Temperature Stability	±2°C
Maximum Hot Inlet Temperature	85°C
DO8 Working Pressure Range	1.0 to 5.0 bar : High Pressure
Min Temp Differential (Mix to Hot) for Fail-Safe	10°C
Max. Pressure Inlet Differential	5 : 1
Max. Flow Rate @ 1 bar Differential	Ø15mm 1500 l/h (25 l/m) Ø22mm 1700 l/h (28.3 l/m)

Operating Pressure Range	High Pressure	Low Pressure
Maximum Static Pressure	10 bar	10 bar
Flow Pressure, Hot and Cold	1 to 5 bar	0.2 to 1 bar
Hot Supply Temperature	55°C to 65°C	55°C to 65°C
Cold Supply Temperature	5°C to 20°C	5°C to 20°C

NOTE: Valves operating outside these conditions cannot be guaranteed by the Scheme to operate as Type 3 valves.

Approvals

TMV3 Scheme Approval Number: Details Available on Request

WRAS Scheme Approval Number: Details Available on Request

Fail Safe Function

The Intatherm thermostatic basin tap is designed to stop the mixed water flow in the event of either the hot or cold water supply failing when installed in accordance with these instructions.

To ensure full closure of the mixed water flow minimum temperature differential between the hot water inlet to the tap and mixed water outlet **MUST be at least 10°C.**

Application

The Intatherm thermostatic basin tap has been independently tested by the NSF Testing and Evaluation Centre and certified as meeting the requirements of the NHS D08 specification under the TMV3 Scheme as being suitable for use on the following designations;

Wash Hand Basin **HP-W**

Temperature Setting

Ensure that the basin tap is commissioned under normal system conditions. The basin tap **MUST** be commissioned to suit site conditions and the desired outlet temperature set by the installer;

- i With normal supply conditions established and the hot and cold water supplies running, open the basin tap to its maximum temperature and leave running.
- ii Remove the indice, retaining screw and handle by pulling away from the tap and the temperature stop ring, see diagram on page 5.
- iii Fully open the flow control and allow the outlet temperature to stabilise.
- iv Temporarily refit the handle and using a digital thermometer it is possible to increase or reduce the mixed water outlet temperature until 38°C is re-established, by slowly rotating the handle.
- v Remove the handle and refit the temperature stop ring onto the splined section of the cartridge at the maximum temperature position.
- vi Refit the handle in the reverse order.

Installation

IMPORTANT - The following instructions must be read prior to the installation of any Inta basin tap. The installer should also be aware of their responsibility and duty of care to ensure that all aspects of the installation comply with all current regulations and legislation.

Flushing through water systems using certain chemicals may wholly or partially remove the lubricant from the internal workings of the tap, which may adversely affect its performance. We recommend that following a flushing of the system with chemicals, valves are checked for correct operation.

- 1 It is essential that before installing an Intatherm thermostatic basin tap to ensure that the supply conditions of the system, to which the tap is intended to be fitted, are checked to confirm compliance with the parameters as quoted within the Technical Specification and conditions on which the approval is granted i.e. verify supply temperatures, supply pressures, risk assessment.
- 2 Consideration must be made for the possibility of multiple / simultaneous demands being made on the supply system whilst the basin tap is in use, all practical precautions must be made to ensure that the basin tap is not affected. Failure to make provision within the pipe sizing etc. will affect the performance of the tap.

Installation

- 3 The supply system to which the Intatherm thermostatic basin tap is to be installed into must be thoroughly flushed and cleaned to remove any debris, which may have accumulated during the installation. Failure to remove any debris will affect the performance and the manufacturer's warranty of the product.

In areas that are subject to aggressive water, provision must be made to treat the water supply prior to the supply entering any product.

- 4 The maximum flow rate of the tap will only be achieved when the supply conditions are achieved as quoted within the Technical Specification, with a flow condition under 1 bar differential pressure.
- 5 This thermostatic mixer tap has been designed for basin mounting. It is essential that access to the tap is not be obstructed for commissioning, testing, or any future maintenance that may be required.
- 6 The hot and cold water supplies must be connected to the tap strictly in accordance with these instructions i.e. hot water supply to the hot port of the tap.
- 7 In a situation where one or both of the water supplies are excessive, it is possible to fit a pressure reducing valve or a flow regulator to reduce the pressure(s) to within the limits as quoted previously.
- 8 Any thermostatic basin tap must be fitted with a back flow prevention device, such as check valves to prevent the cross contamination of supplies.
- 9 Independent filters/check valves and isolation valves must be fitted in conjunction with the IT1005RS and IT1006RS basin taps, as close as practically possible to the water supply inlets.
- 10 It is essential that the Intatherm thermostatic basin tap should not be installed in situations where there is a possibility of the tap being deprived of water or where demands for water are greater than the actual stored supplies.
- 11 To ensure that the performance levels of the Intatherm thermostatic basin tap is maintained (in the event of cold water failure), the temperature of the hot water supply at the point of entry to the valves must be a minimum of 10°C above the commissioned mixed water discharge temperature.
- 12 The Intatherm thermostatic basin tap must not be subject to any extreme temperature variations either during the installation or under normal operating conditions.

Commissioning

IMPORTANT - The following instructions must be read and understood prior to commissioning the Intatherm thermostatic basin tap. If under any circumstances there are aspects to the installation / system which do not comply with the specification laid down, the tap **MUST NOT** be put into operation until the system / installation complies with our specification. However if all these conditions are met, proceed to set the temperature as follows;

- 1 Ensure that the system is thoroughly cleaned and free from any debris prior to the commissioning the Intatherm thermostatic basin tap.
- 2 Commissioning the temperatures must be carried out using a suitably calibrated thermometer preferably a digital thermometer.
- 3 In the absence of other temperatures being specified, we recommend the outlet temperature quoted in Table 1 are used.

Table 1

Application	Recommended Set Mixed Water Temp.
Wash Hand Basin	41°C

- 4 Each basin tap must be commissioned taking into consideration any fluctuations, which may occur within the system due to simultaneous demands. It is advisable that any outlets which are connected to the same supply as the basin tap are opened during the setting of the mixed water temperature. During commissioning it is advisable to ensure that the water temperatures are established before any attempt to commission.
- 5 Once the supply temperatures are stable and the normal operating conditions are established, the tap can be commissioned. The temperature setting can be adjusted following the procedure described earlier in the Temperature Setting section.

We suggest that the following sequence is followed when commissioning the valve:

- 5.1 Set the mixed water temperature to the required temperature.
- 5.2 Measure and record the temperature of the hot and cold water supplies at the connection to the tap.
- 5.3 Measure and record the temperature of the water discharging from the basin tap.
- 5.4 Isolate the cold water supply to the tap and monitor the mixed water temperature.
- 5.5 Measure and record the maximum mixed water temperature and the final temperature. The final temperature found during the test should not exceed the value quoted in Table 2.
- 5.6 Record all the equipment used during the commissioning.

Commissioning

Table 2

Application	Maximum Set Mixed Water Temp.
Wash Hand Basin	43°C

- 6 Ensure that the application, in which the basin tap will be used, is appropriate for the approved designation. The above information must be recorded and updated on every occasion when any work is carried out on the basin tap.

Maintenance

To ensure the Intatherm thermostatic basin tap maintains a high level of we advise the following in service testing is conducted (the same used to commission the basin tap initially must be used in the following tasks).

- 1 After a period of between 6 and 8 weeks from commissioning carry out the following;
 - 1.1 Record the temperature of the hot and cold water supplies.
 - 1.2 Record the temperature of the mixed water from the basin TAP.
- 2 If the mixed water temperature has changed significantly from the previous test results (e.g. $>1^{\circ}\text{K}$), record the change and before resetting the mixed water temperature check that:
 - 2.1 All the strainers are clean.
the check valves are in good working order.
 - 2.3 The isolation valves are fully open.
- 3 If the mixed water temperatures are acceptable, carry out the following:
 - 3.1 Record the temperature of the hot and cold water supplies.
 - 3.2 Record the temperature of the mixed water from the basin tap.
 - 3.3 Isolate the cold water supply to the mixing valve and monitor the mixed water temperature.
 - 3.4 Record the maximum temperature achieved as a result of (3.3) and the final temperature (the final temperature should not exceed the values quoted in table 2)
 - 3.6 Record the equipment used during these tests.
- 4 If the mixed water temperature is greater than the values quoted in table 2 or the maximum temperature exceeds the corresponding values from previous test results by more than 2°K , the basin tap must be serviced.
- 5 After a period of between 12 to 15 weeks from commissioning, carry out the sequence of tests as described in Maintenance sections 1, 2, 3 and 4.

Maintenance

- 6 Dependant upon the results obtained from the first two series of tests; there are a number of possible outcomes:
 - 6.1 If no significant change in the mixed water temperatures (e.g. $\leq 1^{\circ}\text{K}$) is recorded between commissioning and Maintenance sections 1 or between commissioning and Maintenance sections 5, the next in service testing should be carried out at a period of 24 to 28 weeks after initial commissioning.
 - 6.2 If a small change (e.g. 1 to 2°K) in the mixed water temperature is recorded in only one of these periods, necessitating adjustment of the mixed water temperature, then the next in service can be deferred to 24 to 28 weeks after commissioning.
 - 6.3 If small changes (e.g. 1 to 2°K) in the mixed water temperature are recorded in both of these periods, necessitating adjustment of the mixed water temperature, then the next in service test can be deferred to 18 to 21 weeks after commissioning.
 - 6.4 If significant changes (e.g. $> 2^{\circ}\text{K}$) in the mixed water temperature are recorded in both of these periods necessitating service work, then the next in service test should be carried out at 18 to 21 weeks after commissioning.
- 7 The general principle to be observed after the first 2 or 3 in-service tests is that the intervals for future tests should be set to those which previous tests have shown can be achieved with no more than a small change in mixed water temperature.
- 8 In all areas periodic maintenance of the valve and associated fittings i.e. strainers, check valves will ensure optimum performance levels are maintained; Inta recommend this is performed at least annually.

Spares

A full range of spares are available for this product from Inta.

PLEASE NOTE: Only genuine spares should be used.

Notes:

Notes:

inta

Please leave this Manual for the User

To activate your product warranty please visit
www.intatec.co.uk
and click on Product Registration

inta

Intatec Ltd

Airfield Industrial Estate
Hixon
Staffordshire
ST18 0PF

Tel: **01889 272 180**

Fax: **01889 272 181**

email: **sales@intatec.co.uk**

web: **www.intatec.co.uk**

E & O.E