

inta PRESSURE REDUCING VALVES

EN

FEATURES

They are used to reduce the pressure of a fluid, especially in plumbing and heating systems, where the high pressure in the main supply networks needs to be brought down to optimal operating values, constantly below admissible maximum values.

OPERATING PRINCIPLE

With a design based on the compensation chamber system, they allow to annul the variations deriving from changes in delivery pressure values.

Pressure steady at the adjustment value, 3 bar

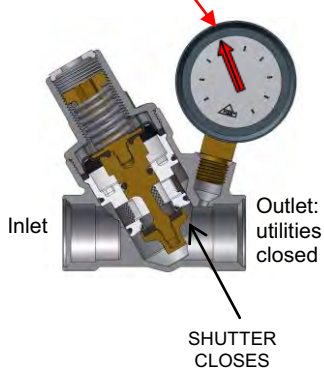

PRESSURE REDUCING VALVE CLOSED

Inlet: high-pressure area
Outlet: low-pressure area with no flow rate

Pressure drop

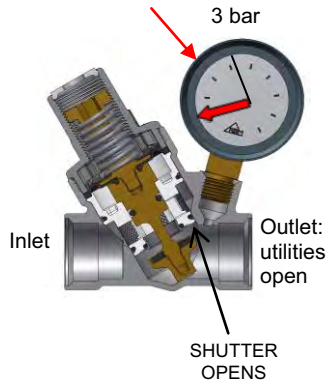

PRESSURE REDUCING VALVE OPEN

Inlet: high-pressure area
Outlet: low-pressure area with flow rate required for the utility and related to the pressure drop

kiwa  *
KIP 087598



15mm, 22mm,
1/2" & 3/4" Valves



28mm - 54mm
& 1" - 2" Valves

* Compliant with EN 1567, and certified Kiwa by RBM s.p.a

** Korea water and wastewater works association (KWWA).

CONSTRUCTIONAL FEATURES

Body	CW 602 N UNI EN 12165 Brass
Metal used for inner parts	CW 614 N UNI EN 12164 Brass CW 602 N UNI EN 12164 Brass
Internal cartridge	POM
Filter	AISI 302 stainless steel
Gaskets	O1/B70 NBR Nitrile elastomer
External plastic parts	Nylon 6 with 30% glass fibre
Pressure gauge-holder connection	F G 1/4"
Connections	FF UNI-EN-ISO 228 (15mm, 22mm, 1/2" & 3/4" Valves) or copper compression pipe MM UNI-EN-ISO 228 (28mm - 54mm & 1" - 2" Valves) or copper compression pipe

TECHNICAL FEATURES

Compatible fluid	Water
Maximum upstream pressure	16 bar (1600 kPa)
Adjustable downstream pressure	0,5+7 bar (50+700 kPa)
Factory presetting (with 8 bar downstream pressure)	3 bar (300 kPa)
Maximum operating temperature	80°C

SETTING THE PRESSURE REDUCING VALVE

The final setting of the pressure reducing valve must be conducted when the hydraulic circuit is completely full and all the utilities are closed. Otherwise, values would be affected by the fact that, when the water is supplied, the downstream pressure decreases in relation to the required flow rate.

All 15mm, 22mm, 1/2" and 3/4" pressure reducing valves are set by acting on an inner ring nut, by turning it clockwise to increase its value and loosening it anticlockwise to decrease it.

All 28mm-54mm and 1"-2" pressure reducing valves are set by acting on the plastic knob, by turning it clockwise to increase its value and loosening it anticlockwise to decrease it.



15mm, 22mm,
1/2" & 3/4" Valves



28mm - 54mm &
1" - 2" Valves

Determination of the pressure loss in relation to the flow rate.
The values described in the diagram have been obtained with:

- an upstream pressure of 8 bar (800 kPa)
- the pressure reducer calibrated on 3 bar (300 kPa)

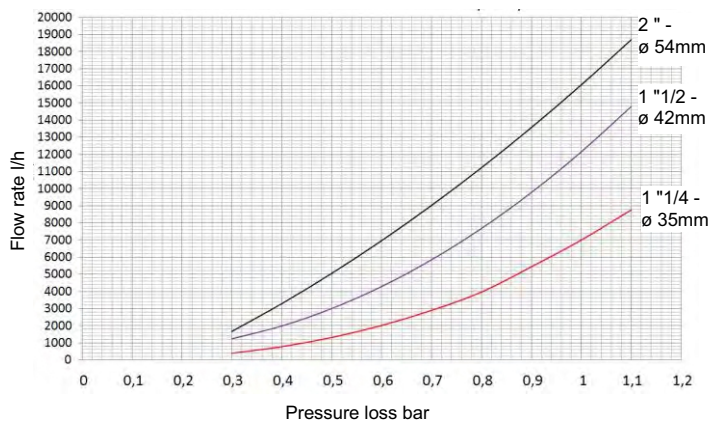
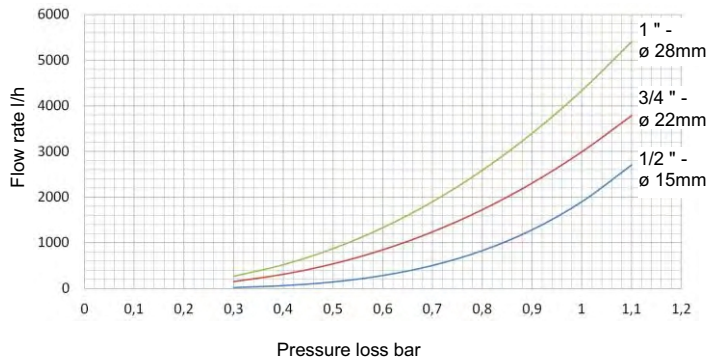

INSTALLATION RECOMMENDATIONS:

- install – upstream and downstream of the reducer – the shut-off valves to perform any maintenance work;
- always envisage the application of a filter upstream of the system;

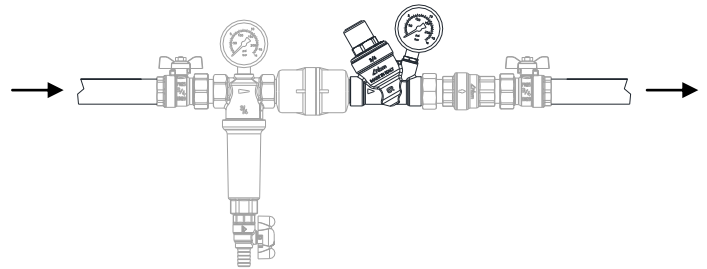

- thoroughly clean the high-pressure pipe upstream of the reducer by flushing several times;
- follow the direction indicated by the arrow on the body;
- set the reducer to the maximum pressure compatible with the system, fully open the downstream flush valve to further clean the pipe;
- close the downstream valves and set the reducer to the desired pressure, shown on the pressure gauge that can be applied to the manometric intake by removing the cap;
- flush a few times to check the stability of the setting;
- if the system includes tanks or devices with an operating pressure lower than the pressure of the network upstream of the reducer, when this is installed always fit the safety valves required to protect the tanks or devices.

WARNING: When the system is running, the pressure detected by the pressure gauge may be affected by the overpressure of the heating system; any adjustments must be performed when the system is not running and at ambient temperature.

The pressure reducing valve can be installed vertically, horizontally and facing downwards.

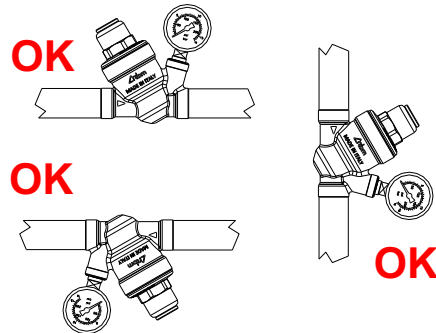

Instructions code IS.2848.0 rev00

Intatec Ltd, Airfield Industrial Estate, Hixon, Staffordshire. ST18 0PF
Tel: 01889 272 180 Fax: 01889 272 181
E: sales@intatec.co.uk w: www.intatec.co.uk