

## LO802CP Floor Mounted Pedal Valve

### Operating Conditions

Max. Inlet Pressure:	5 bar
Min. Inlet Pressure:	0.2 bar
Max. temperature:	65 °C
Connections:	G 1/2"

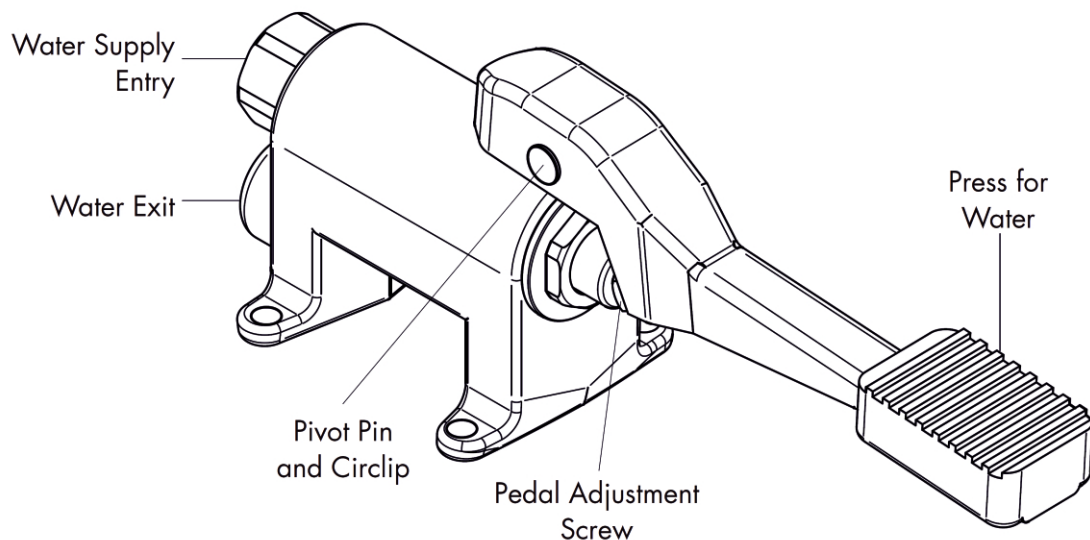

### Water Byelaws

The installation must be carried out in accordance with the Water Supply (Water Fittings) Regulations 1999 and any local authority regulations.

**If used for hot water in order to prevent scalding the hot water supply should be connected to the valve via a thermostatic mixing valve.**

The thermostatic mixing valve should have connections containing an isolating valve and filter, in order to isolate the valve should servicing be required in the future.

If used for cold water it is recommended that a service valve and strainer are installed in the cold water supply pipe.

### Installation

All installations should be thoroughly flushed to remove any debris that may affect the performance of the

valve

The valve should be mounted on a tiled or water proof floor surface.

Position the valve under the sink or basin ensuring that it can be operated easily whilst not being a trip hazard on the floor.

Using the four holes as a template drill holes and fix securely to the floor.

Connect the hot or cold supply pipe and the outlet water pipe as shown.

Turn on the water supply, operate the valve and check all joints for leakage.

### Aftercare

Clean periodically with a soft cloth and mild detergent.

If abrasive or strong cleaners are used to clean the floor avoid splashing or excessive contact.