

LO985CP Contemporary Sequential Spray Lever Handle Basin Mixer Tap



Operating Conditions

Min Operating Press.	0.5 bar
Max Operating Press.	5.0 bar
Max Thickness of basin	45 mm

General information

The LO985CP is a single lever sequential spray mixer tap that will provide a spray of water, giving cold to hot with 90 degrees of movement of the lever handle via a ceramic disc cartridge.

Installation

Your Inta tap must be installed in accordance with the Water Byelaws.

In order to prevent scalding, the hot water tap should be connected to the hot water supply via a thermostatic mixing valve.

It is recommended that a service valve is installed in the cold water supply pipe and the thermostatic mixing valve should have connections containing an isolating valve, should servicing be required in the future.

All installations should be thoroughly flushed and cleaned to remove any debris that may affect the performance of the tap.

The LO985CP mixer tap is designed for installing in one hole basins.

Fit the base plate (11) into the tap body (10).

Screw the retaining screw (16) into the threaded hole in the base of the body taking care not to over tighten.

Connect the copper tails (15) to the tap and tighten noting which copper tail is connected to the hot side of the tap.

The hot supply must be connected to the left hand side and the cold to the right hand side of the tap when viewed from the front.

Ensure that the circular rubber gasket (12) is seated correctly in the recess of the base plate (11) prior to fitting the tap to the basin.

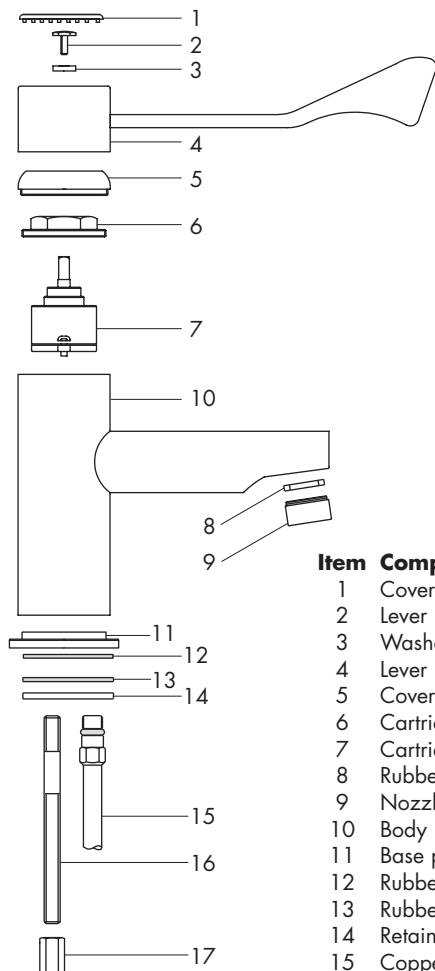

Item	Component
1	Cover
2	Lever retaining screw
3	Washer
4	Lever
5	Cover
6	Cartridge retainer
7	Cartridge
8	Rubber washer
9	Nozzle
10	Body
11	Base plate
12	Rubber gasket
13	Rubber gasket
14	Retaining plate
15	Copper tail
16	M8 Retaining screw
17	Retaining nut

LO985CP Contemporary Sequential Spray Lever Handle Basin Mixer Tap

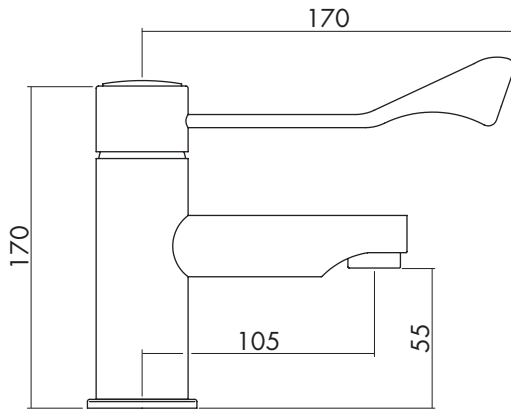

Installation Cont.

Once in place, add the profiled rubber gasket (13) and retaining plate (14) then secure in position, taking care not to over tighten the retaining nut (17).

Connect the copper tails to the hot and cold supplies remembering which was connected to the hot inlet and ensure all joints are water tight.

For optimum mixing performance where the hot and cold pressures are not equal, regulating valves should be installed directly upstream of the tap so that the water supply pressures can be regulated and equalised.

For multiple installations there may be starvation of flow to the furthest tap on the supplies, when all the taps are operated simultaneously. It may be necessary to balance the flow to each tap, using the regulating valves.

Operating

The lever can be rotated through 90° from inline to the right.

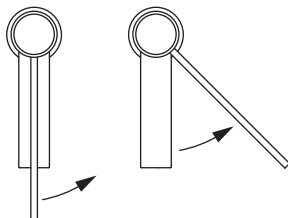

To operate the tap, turn the lever in the anticlockwise direction, this will progressively open the cold water port and allow cold water to flow.

If the lever is rotated further anticlockwise this will open the hot water port, whilst partially closing the cold water port, giving a mixed water temperature flow.

If the lever is rotated further anticlockwise the cold water port will close fully and the hot water port will fully open. This will allow the maximum hot water temperature to be obtained.

Servicing Instructions

The tap should be periodically serviced to maintain optimum performance.

Remove the cover (1), lever (4), cover (5) and cartridge retainer (5) using a suitably sized spanner.

The internal cartridge (7) can be pulled from the body. Do not attempt to dismantle any part of the cartridge, if necessary replace with a new cartridge.

Remove any debris that may have collected within the body and ensure that the stem on the cartridge rotates freely.

Re-assemble the cartridge (7) into the body using washing-up liquid as a lubricant if necessary to ease assembly and prevent damage to the 'O' ring seal.

Re assemble in the reverse order

Aftercare

The nozzle should be cleaned periodically to remove any build up of debris or deposits which may affect the performance of the tap.

Ensure that a suitably sized spanner is used to remove the nozzle (9). With all highly polished items care should be taken not to damage the surfaces.

Inta mixers have a high quality finish and should be treated with care. An occasional wipe with a mild washing-up liquid on a soft damp cloth followed by a thorough rinsing is all that is required.

Do not use an abrasive or chemical household cleaner as this may cause damage.