

NC230CP Non Concussive Basin Tap with Flexible Tails Installation and Operating Instructions



Operating Conditions

Min Operating Pressure:	1.0 bar
Max Operating Pressure:	6.0 bar
Max Inlet Temperature:	65°C
Timed Flow @ 1 bar:	15 ± 3 sec
Max. Thickness of basin:	45 mm

General Information

The NC230CP is a non concussive basin tap with manual temperature adjustment.

Turn the control knob clockwise to increase the mixed water temperature and anti-clockwise to reduce it.

Pressing the control knob turns on the tap.

Installation

Your Inta basin mixer must be installed in accordance with the Water Byelaws.

In order to prevent scalding, the hot water supply should be connected to the mixer via an Intamix TMV.

It is recommended that a service valve is installed in the cold water supply pipe and the thermostatic mixing valve should have connections containing an isolating valve, in order to isolate the mixer should servicing be required in the future.

All installations should be thoroughly flushed and cleaned to remove any debris that may affect the performance of the mixer.

This mixer tap is designed for installing in one hole basins.

Fit the base plate onto the tap body.

Screw the retaining screw (1) into the threaded hole in the base of the body taking care not to over tighten.

Connect the flexible tails (5) to the tap and tighten noting which copper tail is connected to the hot side of the tap.

The hot supply must be connected to the left hand side and the cold to the right hand side of the mixer when viewed from the front.

Ensure that the sealing washer (2) is seated correctly in the recess of the base plate prior to fitting the mixer to the basin.

Once in place, add the retaining plate (3) then secure in position, taking care not to over tighten the retaining nut (4).

For optimum mixing performance where the hot and cold pressures are not equal, regulating valves should be installed directly upstream of the mixer so that the water supply pressures can be regulated and equalised.

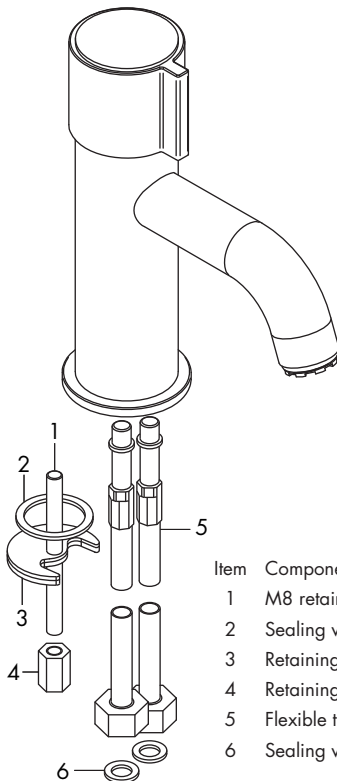

Item	Component
1	M8 retaining screw
2	Sealing washer
3	Retaining plate
4	Retaining nut
5	Flexible tail
6	Sealing washer

NC230CP Non Concussive Basin Tap with Flexible Tails Installation and Operating Instructions

Push down fully to turn
on mixed water

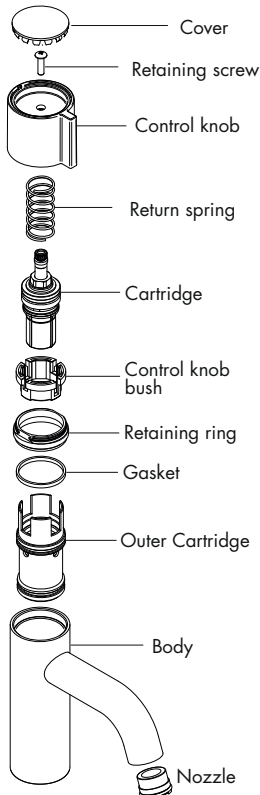
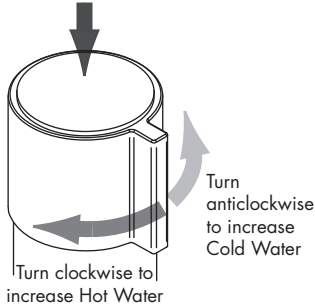

Operating

To turn on the mixer push down on the control knob until it contacts a stop and then release, mixed temperature water will flow for approximately 15 seconds.

If more water is required push again.

Rotating the control knob anticlockwise progressively closes the hot water port and opens the cold water port until it is fully open when only cold water flows when the mixer is turned on.

Rotating the control knob clockwise progressively closes the cold water port and opens the hot water port until it is fully open and water at the maximum temperature flows when the mixer is turned on.

Aftercare

The aerator should be cleaned periodically to remove any build up of debris or deposits which may affect the performance of the mixer.

Inta mixer taps have a high quality finish and should be treated with care.

An occasional wipe with a mild washing-up liquid on a soft damp cloth followed by a thorough rinsing is all that is required.

Do not use an abrasive or chemical household cleaner as this may cause damage.

Servicing Instructions

If the control knob cannot be depressed fully or does not return to its initial position within 15 seconds, or the temperature cannot be adjusted easily or water does not flow in a steady stream the mixer may require servicing.

Turn off the hot and cold supplies to the mixer.

Remove the cover, unscrew the retaining screw and carefully remove the control knob ensuring the return spring does not escape and cause injury.

Using a suitably sized spanner remove the cartridge from the body.

Remove any debris that may have collected within the body, ensure the stem rotates freely and can be depressed.

Do not attempt to dismantle any part of the cartridge, if necessary replace with a new cartridge.

Check the 'O' rings and return spring for any sign of damage and replace if necessary.

Using washing up liquid as a lubricant, to ease assembly and prevent damage to the 'O' rings, re-assemble the cartridge into the body and tighten.

Re-assemble the other components in the reverse order and turn on the water supplies.

Check the mixer for correct operation.