

Intamix Pro V Thermostatic Mixing Valves

Introduction

The Intamix Pro V range is designed for use in applications where a high volume of water is required at the outlet such as shower blocks and centralised mixing. Providing a high volume of water at a stable temperature, the Intamix Pro V reflects the quality of the intatec range of total washroom solutions.

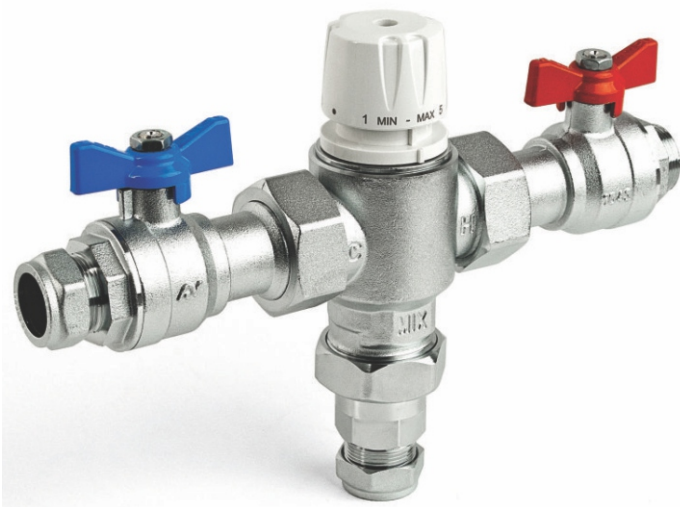

- Thermostatic protection
- Tamper proof head
- Single piece thermostatic cartridge construction
- high flow rate, low pressure drops
- Adjustable outlet temperature
- Temperature stability of +/-2°C
- Inline isolation valves and check valves

Product Range

Description	Code
Intamix pro v 22mm with isolating unions	61022CPB
Intamix pro v 28mm with isolating unions	61028CPB

Intamix Pro V Thermostatic Mixing Valves

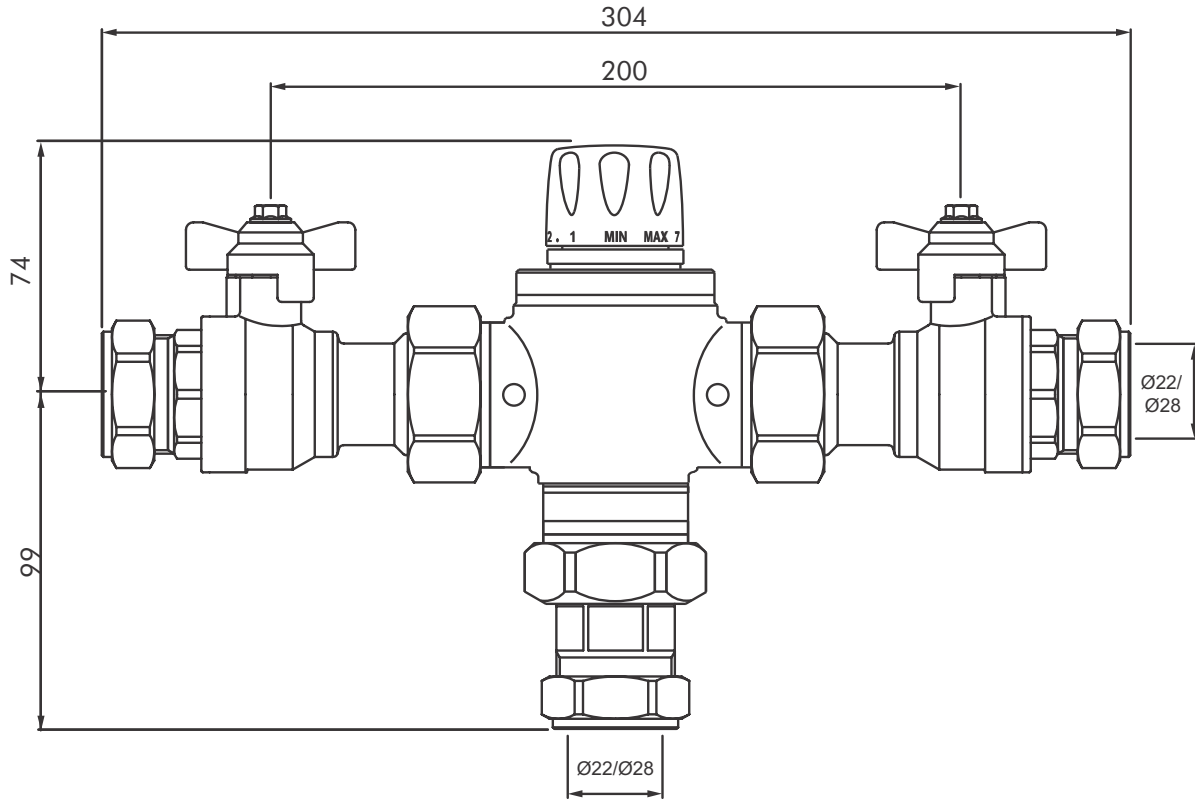

Pressure Differential

Flow Rate

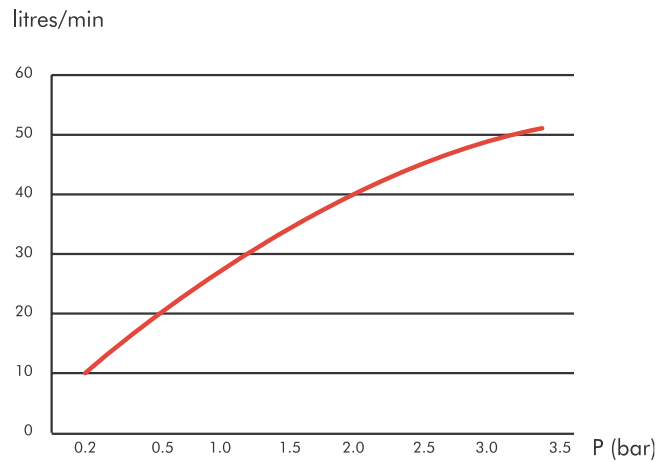
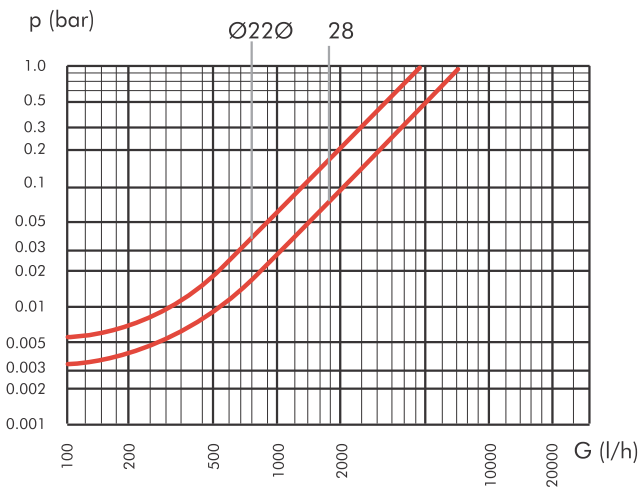

Size	22 _{mm}	28 _{mm}
Kv(m ³ /h)	4.0	4.5